

Алматы (7273)495-231  
Ангарск (3955)60-70-56  
Архангельск (8182)63-90-72  
Астрахань (8512)99-46-04  
Барнаул (3852)73-04-60  
Белгород (4722)40-23-64  
Благовещенск (4162)22-76-07  
Брянск (4832)59-03-52  
Владивосток (423)249-28-31  
Владикавказ (8672)28-90-48  
Владимир (4922)49-43-18  
Волгоград (844)278-03-48  
Вологда (8172)26-41-59  
Воронеж (473)204-51-73  
Екатеринбург (343)384-55-89

Иваново (4932)77-34-06  
Ижевск (3412)26-03-58  
Иркутск (395)279-98-46  
Казань (843)206-01-48  
Калининград (4012)72-03-81  
Калуга (4842)92-23-67  
Кемерово (3842)65-04-62  
Киров (8332)68-02-04  
Коломна (4966)23-41-49  
Кострома (4942)77-07-48  
Краснодар (861)203-40-90  
Красноярск (391)204-63-61  
Курск (4712)77-13-04  
Курган (3522)50-90-47  
Липецк (4742)52-20-81

Магнитогорск (3519)55-03-13  
Москва (495)268-04-70  
Мурманск (8152)59-64-93  
Набережные Челны (8552)20-53-41  
Нижний Новгород (831)429-08-12  
Новокузнецк (3843)20-46-81  
Ноябрьск (3496)41-32-12  
Новосибирск (383)227-86-73  
Омск (3812)21-46-40  
Орел (4862)44-53-42  
Оренбург (3532)37-68-04  
Пенза (8412)22-31-16  
Петрозаводск (8142)55-98-37  
Псков (8112)59-10-37

Пермь (342)205-81-47  
Ростов-на-Дону (863)308-18-15  
Рязань (4912)46-61-64  
Самара (846)206-03-16  
Саранск (8342)22-96-24  
Санкт-Петербург (812)309-46-40  
Саратов (845)249-38-78  
Севастополь (8692)22-31-93  
Симферополь (3652)67-13-56  
Смоленск (4812)29-41-54  
Сочи (862)225-72-31  
Ставрополь (8652)20-65-13  
Сургут (3462)77-98-35  
Сыктывкар (8212)25-95-17  
Тамбов (4752)50-40-97

Тверь (4822)63-31-35  
Тольятти (8482)63-91-07  
Томск (3822)98-41-53  
Тула (4872)33-79-87  
Тюмень (3452)66-21-18  
Ульяновск (8422)24-23-59  
Улан-Удэ (3012)59-97-51  
Уфа (347)229-48-12  
Хабаровск (4212)92-98-04  
Чебоксары (8352)28-53-07  
Челябинск (351)202-03-61  
Череповец (8202)49-02-64  
Чита (3022)38-34-83  
Якутск (4112)23-90-97  
Ярославль (4852)69-52-93

Россия +7(495)268-04-70

Казахстан +7(7172)727-132

Киргизия +996(312)96-26-47

[www.santeh.nt-rt.ru](http://www.santeh.nt-rt.ru) | | [vhi@nt-rt.ru](mailto:vhi@nt-rt.ru)

# Технические характеристики на плитку керамическую, напольную, декоративную

**Коллекции:** BOURGOGNA, SPARKS, SOLID TONES, SILENT MOOD, OHIO, CODE 2, URBAN ART, STAGEART, Cadiz, Hudson, Section, Loving & Living Tiles, The Art of Simplicity, VILBOGARDEN, Edition C, PURE BASE, MEMPHIS GARDEN, MY EARTH GARDEN, OAK LINE GARDEN, OAK SIDE, RESTONICA.

# RESTONIC

*Natural stone look and a rustic relief*



Calm and gentle and at the same time wild and rough - the RESTONICA wall concept adapts the character of original nature, as seen in the spectacular Restonica Valley in Corsica, and transfers it into ceramics. Inspired by the rocky mountain landscape, pools shining in the sun and powerfully bubbling waterfalls, the concept combines smooth stoneware tiles with an authentic stone look with an elaborate relief decoration that invites you to touch it: the coarse structures of the decors stand in strong contrast to the fine basic tiles - impressively laid over a large area or accentuated as a band or pattern.

The glazed tiles, available in two current formats, are perfect for modern wall designs throughout the house. With the natural tones cream, greige and anthracite, they create a clear, pure or a subtle, rustic room atmosphere, depending on the combination with other colors and materials. Special plus: The easy-care CeramicPlus surface ensures thorough cleanliness without much effort - water and a splash of mild cleaner are all you need. This saves time and money and protects the environment.

The ROCKY.ART series supplies matching floor tiles made of **Vilbo Stone with a design that recreates an unusual symbiosis of natural stone and concrete**. Or you can install the gently relief HUDSON porcelain stoneware with a natural, puristic sandstone look.

The tiles shown are licensed products from V&B Fliesen GmbH

## PURE BASE

*Wall and floor concept in a concrete look - puristic concrete design with patchwork decoration*



Clear and pure or slightly rustic – concrete is both! If you combine it with white walls and modern furniture, it shows its minimalist side, and together with warm colors and wood it looks natural. Just like the high-quality PURE BASE tile series, which combines a contemporary concrete look with the convincing practical advantages of ceramic. The Concept<sup>3</sup> series includes porcelain stoneware tiles with **Vilbostone** Plus surface and matching stoneware wall tiles with **Ceramic** Plus, which are easy to clean and maintain, robust and durable.

From warm cream to soft gray nuances to strong anthracite - five harmonious, combinable colors in four formats form the perfect basis for designs that discreetly emphasize the design statement and style of the furnishings and yet shape the room atmosphere. A special plus: Thanks to the R10B slip resistance, all formats can also be installed in the shower, of course at the same level as the floor. This creates a beautiful floor covering in the entire bathroom, as if it were made from a single piece.

The wall tiles from PURE BASE reproduce the slightly cloudy concrete design in light colors a touch more delicately. The highlights are the decorative tiles made of glazed porcelain stoneware, which interpret historically inspired tile patterns as a patchwork in a subtle used look.

## OAK SIDE

*Wall and floor concept with an authentic wood look – OAK SIDE: Elegant oak design meets gentle naturalness*



Regardless of whether it is used as furniture or as wall and floor coverings – wood gives every room a homely atmosphere with a natural flair. Local woods are in great demand in current interior design, and oak is the absolute number 1. Reason enough to combine an authentic oak wood look with the convincing advantages of high-quality ceramics: With OAK SIDE, floors and walls can be designed with an attractive wood look and are much easier to care for, more robust, less sensitive and much more durable than coverings made of real wood.

The design of OAK SIDE is reminiscent of noble oak. **The matt porcelain stoneware tiles, with the easy-care Vilbostone Plus surface**, available in four shades of brown ranging from light to dark and in the two typical formats of 30 x 120 cm and 20 x 120 cm, create a pleasantly warm atmosphere and therefore fit in perfectly with current trends Interior design: Light woods that convey a gentle naturalness and coziness are just as popular in natural living as in classic interiors and in modern, puristic living environments.

The light relief of the light stoneware wall tiles is very discreetly reminiscent of wooden structures - perfect for fine wall coverings, which are particularly easy to clean and care for thanks to the **Ceramic Plus surface finish**.

# OAK LINE GARDEN

Pleasantly natural charisma



Full of peace and comfort, the **OAK LINE GARDEN** series interprets a gentle oak structure in fine stoneware. The light shades of milk and caramel appear fine and light, while the multicolored walnut creates pleasant warmth. Whether furnished in a fresh Scandinavian style or with a southern flair, the authentic design spreads a sense of well-being.

## Choose your color

---



**Milk  
matt**

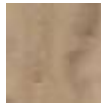

**Caramel  
matt**



**Nut  
matt**

---

## Choose your format

---

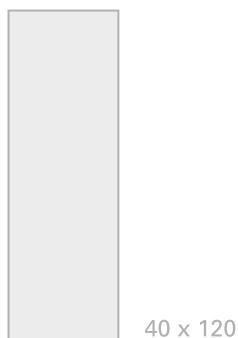

# MEMPHIS GARDEN

The simple look of concrete around the house



Pure concrete look is ideal for timeless, modern designs around the house: whether balcony or terrace, garden path, driveway or carport - the simple appearance of concrete creates a clear minimalism that suits many lifestyles. The MEMPHIS GARDEN tile series, which was specially developed for outdoor applications, transfers the typical look of urban exposed concrete with harmoniously coordinated gray tones and a slightly relief surface to high-quality VilboStone fine stoneware.

The 30 mm thick tiles in a large square format of 80 x 80 cm are particularly robust and therefore ideal for heavily used areas such as garage entrances. The slightly rounded edges emphasize the original concrete character of the covering and thus give the floor surfaces a particularly authentic look. The tiles are lightfast, colorfast and weatherproof and, thanks to the easy-care vilbostonePlus surface - in contrast to real concrete - look just as good as they did on the first day, even after many years of sun, rain, frost and snow, even without any special cleaning or care effort . With their high slip resistance, they also ensure safe footing even when wet.

Choose your color

---



**Silver grey  
matt**



**Dark grey  
matt**



**Warm grey  
matt**

---

Choose your format

---

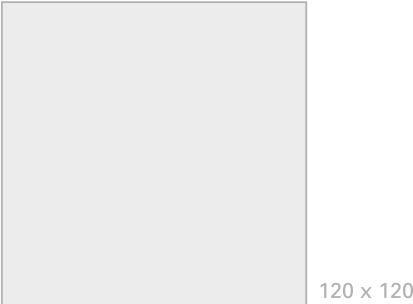
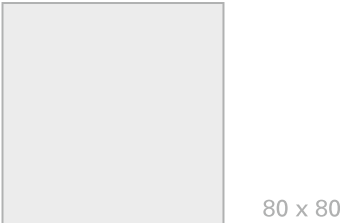
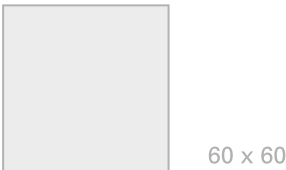

## EDITION C

*Versatile color concept for the wall – ÉDITION C: freedom of design with soft and strong tones*



Calm and consistently reduced to the essentials - Édition C offers everything that makes up a minimalist and at the same time versatile wall concept: a contemporary format, two surfaces, ten colors and therefore numerous options for individual color designs in modern living.

With three warm tones, four cool nuances and three strong colors that all work together, the stoneware tiles enable both harmonious and accentuated combinations - from soft, calm tone-on-tone installations to bold, colorful walls.

The two surfaces provide additional impulses. The matt tiles confidently put the color itself in the foreground, while the shiny ones play with light and shadow. And a mix of matt and glossy ceramics creates interesting effects that constantly change depending on the viewer's position and perspective.



# DAYTONA

## Переосмысленное качество жизни – плитка для современного интерьера



Гармонично, ясно, практично и просто привлекательно. Плитка для пола DAYTONA благодаря своему вневременному облику бетона позволяет создавать функциональные и в то же время привлекательные напольные покрытия в современном интерьере.

DAYTONA изготовлена из керамогранита *vilbostone* и доступна в четырех сдержанных оттенках – для теплой или прохладной атмосферы интерьера. Матовая слегка рельефная плитка настолько прочная, что ее можно укладывать по всему дому – от прихожей и жилой зоны до кухни и ванной комнаты. С помощью подходящей мозаики, доступной во всех цветах, можно создавать декоративный дизайн стен и душевые кабины на уровне пола.

Благодаря сдержанному дизайну современная серия плитки одинаково идеально подходит как для простых в уходе студий, так и для квартир для целой семьи, и, таким образом, будет интересна как для частных застройщиков, так и для строительных подрядчиков и управляющих компаний. В качестве подходящей настенной плитки рекомендуется использовать белую и кремовую плитку серии UNIT TWO с матовой или глянцевой поверхностью.

## Выберите цвет

---



кофе с  
молоком  
матовая



матовая



бежевый  
матовая

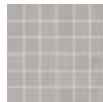

матовая



матовая

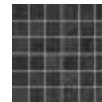

матовая

---

## Выберите формат

---



# INHALTSVERZEICHNIS

– VILBOGARDEN .....	4
Eigenschaften & Vorteile .....	5
CÁDIZ <small>GARDEN</small> .....	6
LUCCA <small>GARDEN</small> .....	10
MEMPHIS <small>GARDEN</small> .....	18
MONT BLANC <small>GARDEN</small> .....	26
MY EARTH <small>GARDEN</small> .....	36
OAK LINE <small>GARDEN</small> .....	44
OAK PARK <small>GARDEN</small> .....	48
URBAN JUNGLE <small>GARDEN</small> .....	52
– FORMTEILE .....	56
– PRODUKTÜBERSICHTEN .....	60
– TECHNISCHE DETAILS .....	69
Technische Eigenschaften .....	69
Verlegearten .....	70
Reinigung und Pflege .....	73
Nachhaltiges Bauen .....	74

Randplatte mit Tropfkante

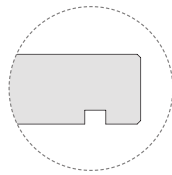
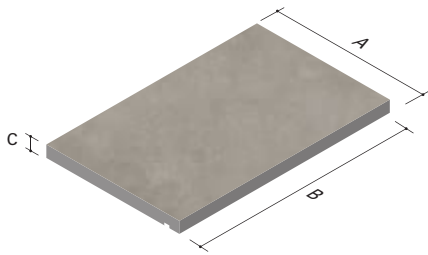

	A (mm)	B (mm)	C (mm)	Art.-Nr.
	295	595	20	28S3
	395	795	20	28S4
	395	1195	20	28S1

Randplatte mit Tropfkante

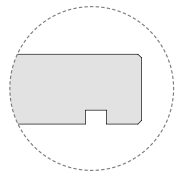
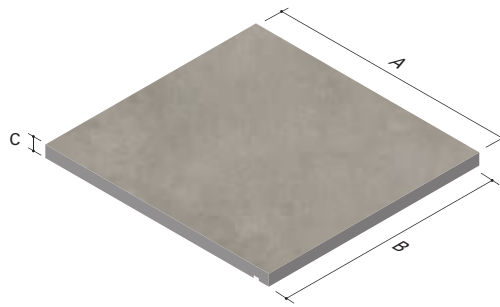

	A (mm)	B (mm)	C (mm)	Art.-Nr.
	595	595	20	28S6
	795	795	20	28S8

Randplatte gerundet mit Tropfkante

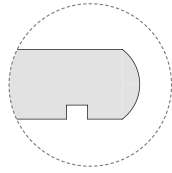
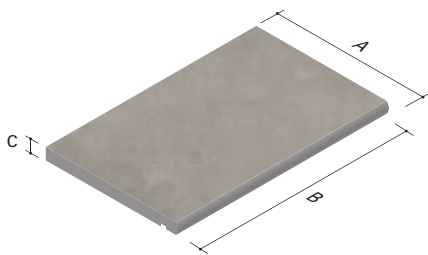

	A (mm)	B (mm)	C (mm)	Art.-Nr.
	295	595	20	28R3
	395	795	20	28R4
	395	1195	20	28R1

Randplatte gerundet mit Tropfkante

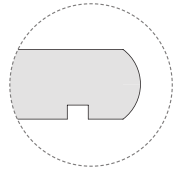
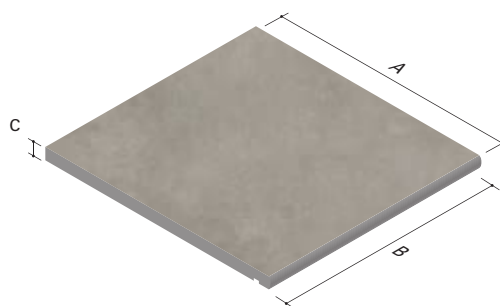

	A (mm)	B (mm)	C (mm)	Art.-Nr.
	595	595	20	28R6
	795	795	20	28R8

Schenkelplatte

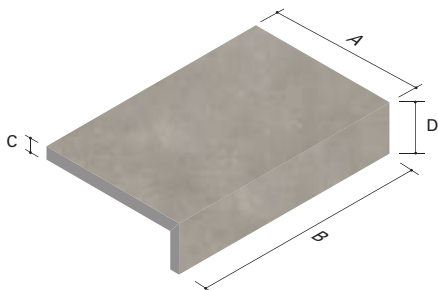

	A (mm)	B (mm)	C (mm)	D (mm)	Art.-Nr.
	350	595	20	145	28W3
	350	795	20	145	28W4
	350	1195	20	145	28W5

Schenkelplatten-Ecke (rechts oder links)

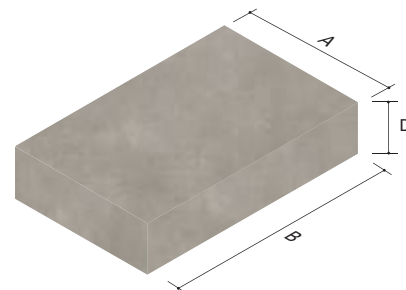

	A (mm)	B (mm)	D (mm)	Art.-Nr.
	350	595	145	28K3
	350	795	145	28K4
	350	1195	145	28K5

Randplatte mit Tropfkante – Innenecke (2-teilig)

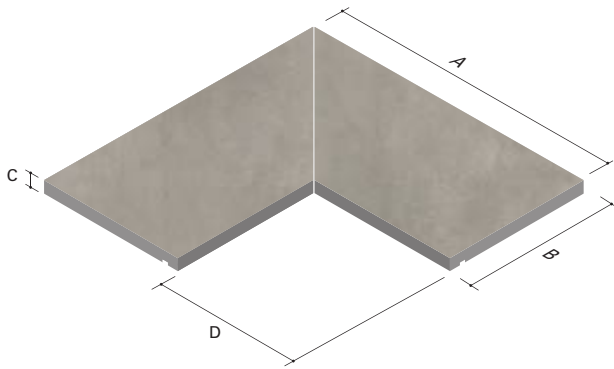

	A (mm)	B (mm)	C (mm)	D (mm)	Art.-Nr.
	591	295	20	296	28F3
	791	395	20	396	28F4
	1191	395	20	796	28F1

Randplatte – Innenecke (2-teilig)

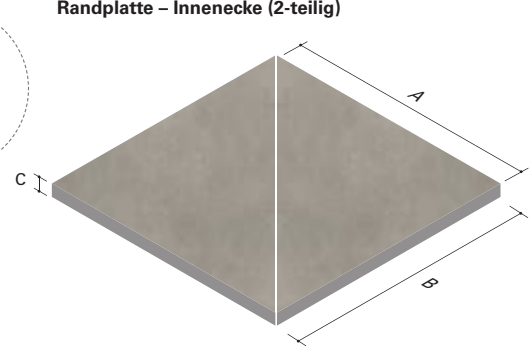

	A (mm)	B (mm)	C (mm)	Art.-Nr.
	591	591	20	28E6
	791	791	20	28E8

Randplatte gerundet mit Tropfkante – Innenecke (2-teilig)

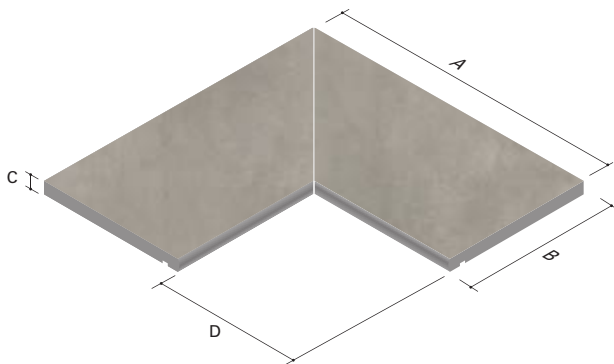

	A (mm)	B (mm)	C (mm)	D (mm)	Art.-Nr.
	591	295	20	296	28E3
	791	395	20	396	28E4
	1191	395	20	796	28E1

Auftragsbezogene Fertigung. Preise und Lieferzeit auf Anfrage.  
Die angegebenen Maße sind die Maximalmaße.  
Geringere Längen/Höhen/Breiten sind auf Anfrage möglich.

Schenkelplatte-Innenecke

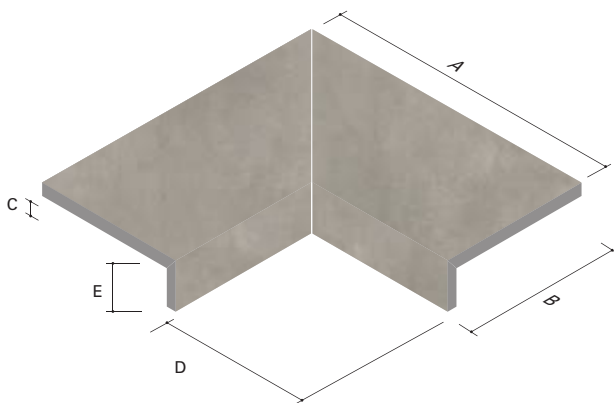

	A (mm)	B (mm)	C (mm)	D (mm)	E (mm)	Art.-Nr.
	591	295	20	296	145	28V3
	791	395	20	396	145	28V4
	1191	395	20	796	145	28V1

Schenkelplatte-Außenecke

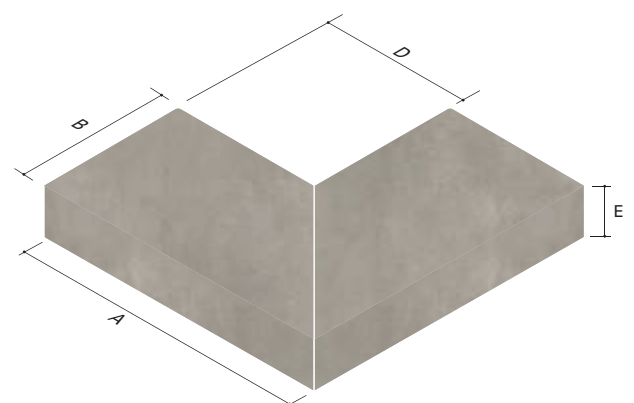

	A (mm)	B (mm)	D (mm)	E (mm)	Art.-Nr.
	591	295	296	145	28Y3
	791	395	396	145	28Y4
	1191	395	796	145	28Y1

## CÁDIZ GARDEN

20

chalk multicolor



60 x 60 x 2 cm



40 x 80 x 2 cm



sand



60 x 60 x 2 cm



40 x 80 x 2 cm



grey multicolor



60 x 60 x 2 cm



40 x 80 x 2 cm



## LUCCA GARDEN

20

sand



60 x 60 x 2 cm

80 x 80 x 2 cm



stone

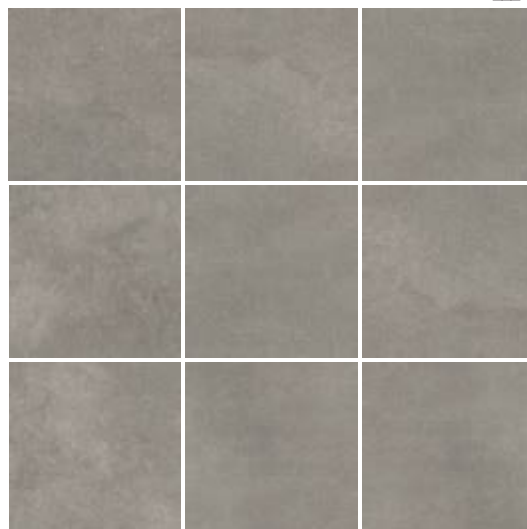

60 x 60 x 2 cm

80 x 80 x 2 cm



rock



60 x 60 x 2 cm

80 x 80 x 2 cm



## MEMPHIS GARDEN

20

silver grey

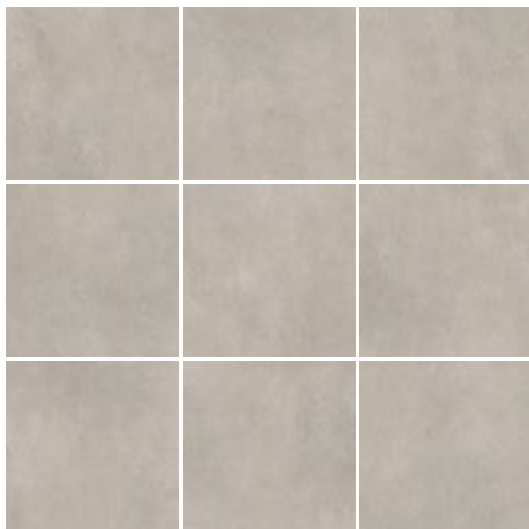

60 x 60 x 2 cm

80 x 80 x 2 cm



warm grey

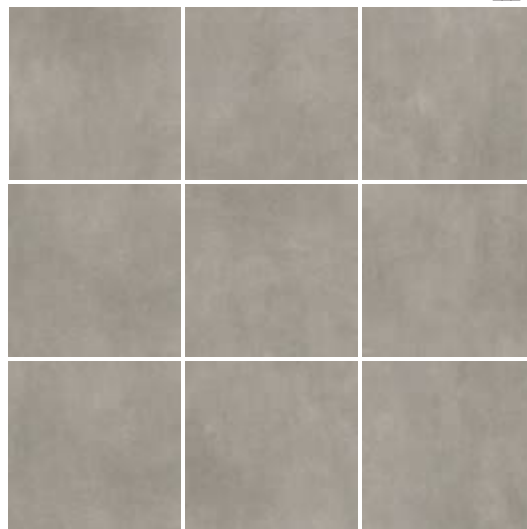

60 x 60 x 2 cm

80 x 80 x 2 cm



dark grey

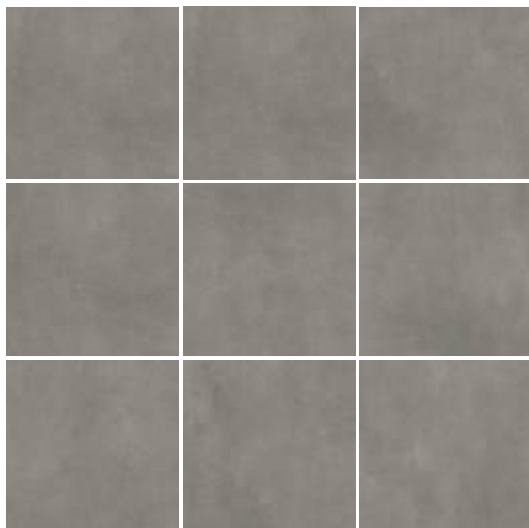

60 x 60 x 2 cm

80 x 80 x 2 cm





## MONT BLANC GARDEN

20

sahara



60 x 60 x 2 cm

80 x 80 x 2 cm



titan

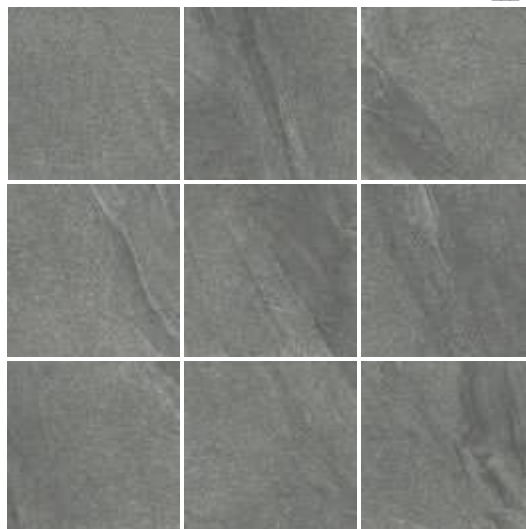

60 x 60 x 2 cm

80 x 80 x 2 cm



silver

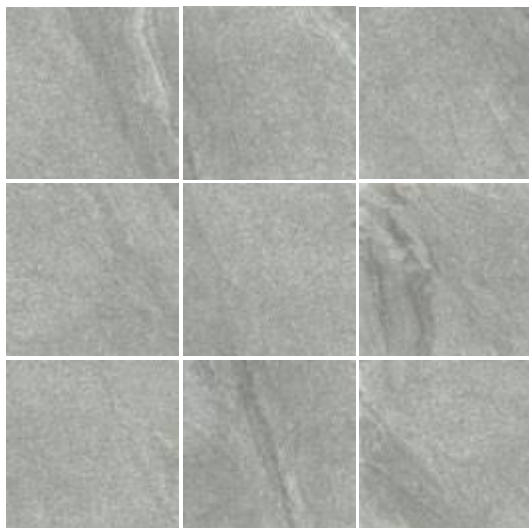

60 x 60 x 2 cm

80 x 80 x 2 cm



carbon

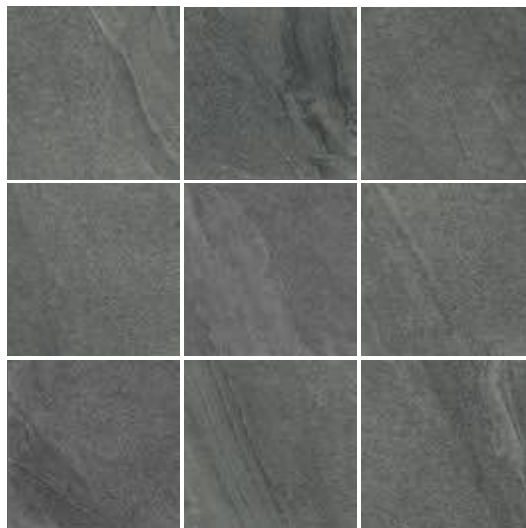

60 x 60 x 2 cm

80 x 80 x 2 cm



MY EARTH GARDEN

20

light beige



60 x 60 x 2 cm    80 x 80 x 2 cm    40 x 80 x 2 cm



beige multicolor



60 x 60 x 2 cm    40 x 80 x 2 cm



grey multicolor



60 x 60 x 2 cm    80 x 80 x 2 cm    40 x 80 x 2 cm



anthracite multicolor



60 x 60 x 2 cm    80 x 80 x 2 cm    40 x 80 x 2 cm



OAK LINE GARDEN

20

milk 3



40 x 120 x 2 cm



caramel 2



40 x 120 x 2 cm



walnut 3



40 x 120 x 2 cm



OAK PARK GARDEN

20

chalete 2



40 x 120 x 2 cm



brandy 2



40 x 120 x 2 cm



## URBAN JUNGLE GARDEN

20

greige



80 x 80 x 2 cm



grey

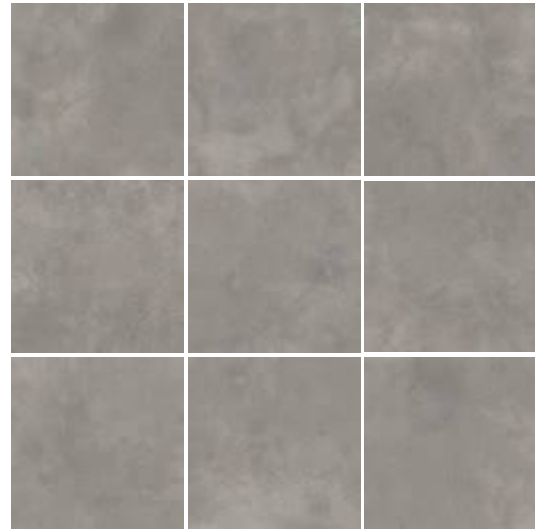

80 x 80 x 2 cm



dark grey



80 x 80 x 2 cm





Villeroy & Boch  
1748

the Art of  
Simplicity

Inhalt / Contents

3	The Art of Simplicity
	<i>Pure &amp; Natural</i>
4	ALTA
10	ROCKY.ART
	<i>Urban &amp; Industrial</i>
14	DAYTONA
16	FALCONAR
22	METALYN
30	OMBRA
	<i>Modern &amp; Classical</i>
34	NOCTURNE
38	Produktübersichten / Product overviews

# the Art of Simplicity

Sich auf die Einfachheit zu beschränken, ist eine Kunst für sich. Gerade in der Inneneinrichtung fällt es schwer, sich von Liebgewonnenem zu trennen und so dem, was uns wirklich wichtig ist, mehr ästhetische Entfaltungsfreiheit zu geben.

Dabei ist es unerheblich, welchen Stil wir bevorzugen. Klassische Formen, natürliche Materialien, moderne Einrichtungen – alles entfaltet mehr Wirkung, wenn nur das Wesentliche im Vordergrund steht. Eine Herausforderung, der sich unsere Designer bei der neuen Fliesenkollektion gestellt haben.

Die neuen Serien sind Symbiosen aus verschiedenen Strukturen, Oberflächenanmutungen und Designs. Authentische Materialien, die mit handwerklichem und gestalterischem Können veredelt werden, schlichte Dekore, die durch ihre strukturierten Oberflächen überzeugen, die Highlights setzen und das Besondere in der Wohnung darstellen.

So erhält Keramik von den Stellenwert, der ihr als natürliches Material mit langlebigen Eigenschaften zukommt. Fliesen können das Wohnen und Leben in ungeahnt schlichter Weise verschönern.

*Keeping things simple is an art in itself. When it comes to home furnishings, it is particularly difficult to part with things we have grown fond of in order to fully reveal the aesthetic appeal of what is really important to us.*

*Whatever style we may prefer - classic forms, natural materials, modern furnishings - everything has a greater effect when only the essentials are in the foreground. Our designers have addressed this challenge with the new tile collection.*

*The new ranges are symbioses of different structures, surface finishes and designs. Authentic materials refined by craftsmanship and accomplished design, simple décors boasting impressive structured surfaces, adding highlights and that special something to the home.*

*This brings out the true essence of ceramics from as natural materials with enduring qualities. Tiles can embellish the home with an unexpectedly simple touch.*

# ALTA

## *Die natürliche Eleganz*

Dezent natürlich –  
doch bei genauem  
Hinsehen exquisit  
elegant: ALTA – ein  
Fliesenkonzept für  
das ganze Haus.

*Discretely natural  
– but on closer  
inspection exquisite-  
ly elegant: ALTA – a  
tile concept for the  
whole home.*





## *Natural elegance*



Eine Symbiose aus schlichter  
Natürlichkeit und erlesenem Design:  
Das Gestaltungskonzept ALTA ist  
ein wohltuend ruhiges, dabei aber  
gestalterisch abwechslungsreiches  
Konzept in verschiedenen Varianten.

*A symbiosis of natural simplicity  
and exquisite design: ALTA features  
a pleasantly calm yet varied design  
concept which comes in a range of  
different variants.*



Bodenfliesen · Floor tiles: ALTA ash  
Wandfliesen · Wall tiles: ALTA silver

*vilbostone* Feinsteinzeugfarben, die sich an der Natur orientieren. Der zarte Quarzit-Glimmer ist das gewisse Etwas – wie geschaffen für das elegante Understatement des modernen Wohnens.



*vilbostone porcelain stoneware colours modelled on nature. The gentle quartzite glimmer adds a special something – perfectly in tune with the elegant understatement of modern home living.*



Bodenfliesen · Floor tiles: ALTA ivory | Wandfliesen · Wall tiles: ALTA silver white, ivory

Leben mit ALTA bedeutet, eine natürliche Atmosphäre zu genießen. Und mehr noch: sich in einzigartigem Stil einzurichten. Die Serie ist eine kreative Konzeption für das ganze Haus – individuell, auserlesen und wertbeständig.

*ALTA conjures up a natural atmosphere in the home. And in unique style. The range is a creative concept for the entire home - individual, exquisite and of lasting value.*

Neben authentisch naturnahen Farben für den Boden sind es vor allem die Wandfliesen, die mit sanft schimmernden Oberflächen und einem Lüstereffekt auf einem dezenten Liniendesign in Räumen Akzente setzen.



Wandfliesen · Wall tiles: ALTA silver white

*Together with authentic natural colours for the floor, it is above all the wall tiles that make their mark in any home scenario, featuring gently shimmering surfaces and a special lustre effect on a discreet linear design.*

**ROCKY.ART***Eine magische Beziehung*

Einfach magisch:  
Die Dekorfliese aus  
Steingut fasziniert  
mit einer hochwertigen  
Glasauflage.

*Magic touch:*  
*The décor tile in*  
*nonvitreous features*  
*fascinating a high-*  
*quality glass overlay.*



Aus einer Kombination  
von Naturstein- und  
Betonanmutungen ist  
ein vielseitiges  
Fliesenkonzept  
entstanden.

*A combination of*  
*natural stone and*  
*concrete looks gives*  
*rise to a multifaceted*  
*tile concept.*

## *A magical pairing*



Bodenfliesen · Floor tiles: ROCKY.ART basalt · pebble | Dekor · Décor: ROCKY.ART magical blue | Wandfliesen · Wall tiles: ROCKY.ART snow

Warum nicht eine blumige Note im Bad? Mit verschiedenen Farben, Dekoren und Formaten aus Steingut und vilbostone Feinsteinzeug inspiriert ROCKY.ART, individuelle Highlights zu setzen. Und so beginnt jeder Tag erfrischend kreativ.

*How about a floral touch in the bathroom? With various colours, décors and formats in nonvitreous and vilbostone porcelain stoneware, ROCKY.ART provides plenty of inspiration for individual highlights. For a refreshingly creative start to every day.*







Natursteinanmutungen und ein puristischer Beton-Look vereinen sich bei ROCKY.ART zu einer stilvollen Symbiose – genau die Kunst, die dem Zuhause die Magie der schlichten Ästhetik verleiht.

*ROCKY.ART combines natural stone finishes and a purist concrete look in consummate style – bringing out the magic of simple aesthetics in the home.*

DAYTONA  
*Wohnqualität  
neu denken*



## *Rethinking quality of life*



Einfach attraktiv: DAYTONA – bietet vier dezent in sich strukturierte Farben und ein dazu passendes Mosaik für dekorative Wandgestaltungen und funktionale bodenebene Duschen. Das zeitlos attraktive Design des vilbostone Feinsteinzeugs ist eine ausgezeichnete Grundlage für modern orientierte Lebensstile - sei es das pflegeleichte Single-Appartement oder das familienfreundliche Eigenheim. Die Fliesen haben eine rutschhemmende Oberfläche, so dass DAYTONA in verschiedensten Räumen eingesetzt werden kann.

*Simply attractive: DAYTONA offers four subtly textured colours and a matching mosaic for decorative wall designs and functional flush-fitting showers. The timelessly attractive design of vilbostone porcelain stoneware provides an ideal basis for modern lifestyles - from the low-maintenance single apartment to the family-friendly home.*

*The tiles feature a slip-resistant finish that makes DAYTONA suitable for use in all types of rooms.*

Bei FALCONAR treffen Industriearchitektur und zeitgemäßes Design aufeinander. Auf einer beton-ähnlichen Struktur durchzieht eine zarte natürliche Netzstruktur die Oberfläche.

*In FALCONAR, industrial architecture meets contemporary design. A natural mesh texture lends a delicate finish to a concrete-like structure.*



FALCONAR

*Ein Netzwerk mit  
charmanten Details*

## *Mesh texture with charming details*

Großzügig – vielseitig – mit einigen Besonderheiten: FALCONAR ist ein Fliesenkonzept für fortschrittliche Urbanität in den eigenen vier Wänden. Der charmante Industriecharakter in einer aparten Used-Optik bietet beste Möglichkeiten, das Zuhause von Grund auf modern und behaglich zu gestalten. Passend zu diesem Ausdruck zeigt das Design der Dekorfliesen schlichte, geometrische Formen – dezent und sehr elegant. Zudem spricht ein technischer Vorteil für den Einsatz der Serie. Die vilbostone Feinsteinzeugfliesen sind mit vilbotouch, einer mikroskopisch feinen, rutschhemmenden Struktur, ausgestattet.

*Generously proportioned and versatile – with a number of special features: FALCONAR is a tile concept for progressive urbanity within your own four walls. The charming industrial character in a striking used look provides an ideal basis for a modern yet congenial feel throughout the home. In keeping with this character, the design of the décor tiles features plain, geometric forms – subtle and very elegant.*

*This range additionally boasts a technical benefit. The vilbostone porcelain stoneware tiles are finished in vilbotouch, a microscopically fine, slip-resistant structure.*





Um in einem minimalistisch eingerichteten Raum einen attraktiven Akzent zu setzen, reicht oft eine einzelne Fliesenreihe mit Dekoren. Die zarte Netzstruktur der Dekorfliese FALCONAR hebt sich dezent von der Fläche ab und entfaltet ihre Wirkung je nach Lichteinfall stärker oder schwächer.

*A single row of tiles with décors is often all it takes to add an attractive highlight to a room appointed in a minimalist style. The delicate mesh structure of the FALCONAR décor tile contrasts subtly with the underlying surface, the intensity of its effect varying according to the incidence of light.*

## METALYN

*Eine Inspiration der  
besonderen Art*



Bewegend schön: das natürlich inspirierte Würfelmuster der Dekorfliesen mit eindrucksvoller 3D-Optik.

*Simply moving: the nature-inspired cube patterns of the décor tiles with an impressive 3D look.*

## *A special source of inspiration*

Ein edles Oberflächenfinish mit metallisch anmutendem Charakter – die Ausgangsbasis für ein extravagantes Gestaltungskonzept. METALYN ist eine Serie in unterschiedlichen Farben, ergänzt durch optisch effektvolle Dekore, die in ihrer Einfachheit eine große plastische Wirkung entfalten. Eine Inspiration der besonderen Art für verschiedenste öffentliche und private Räume.

*A stylish surface finish exuding a metal-like character – the basis for an extravagant design concept. METALYN is a range in various colours, complemented by visually striking décors whose simplicity underscores a pronounced three-dimensional effect.*

*A special source of inspiration for the most diverse types of public and private rooms.*







Trompe-l'œil nennt man den Effekt, der dem Auge vortäuscht, eine Dreidimensionalität zu erleben. So erscheint der Raum noch großzügiger, als er durch das große Format ohnehin schon wirkt.

*"Trompe-l'œil" is a mock 3D effect. This further heightens the spacious feel to the room which is already conjured up by the large format.*

Eine neue Dimension der Gestaltung: METALYN OPTIMA. Die raumhohen Formate eignen sich hervorragend für großzügige Räume und entfalten so ihre ästhetische Funktion. Dies ist nicht nur optisch ein Vorteil, sondern auch ein Plus für die Pflegeleichtigkeit.

*A new dimension in design: METALYN OPTIMA. The room-high formats are ideal for spacious rooms, in which their aesthetic appeal comes into its own. Apart from the visual merits, these formats are also conducive to easy care.*



## OMBRA

# Illusionen im Spiel von Licht und Schatten

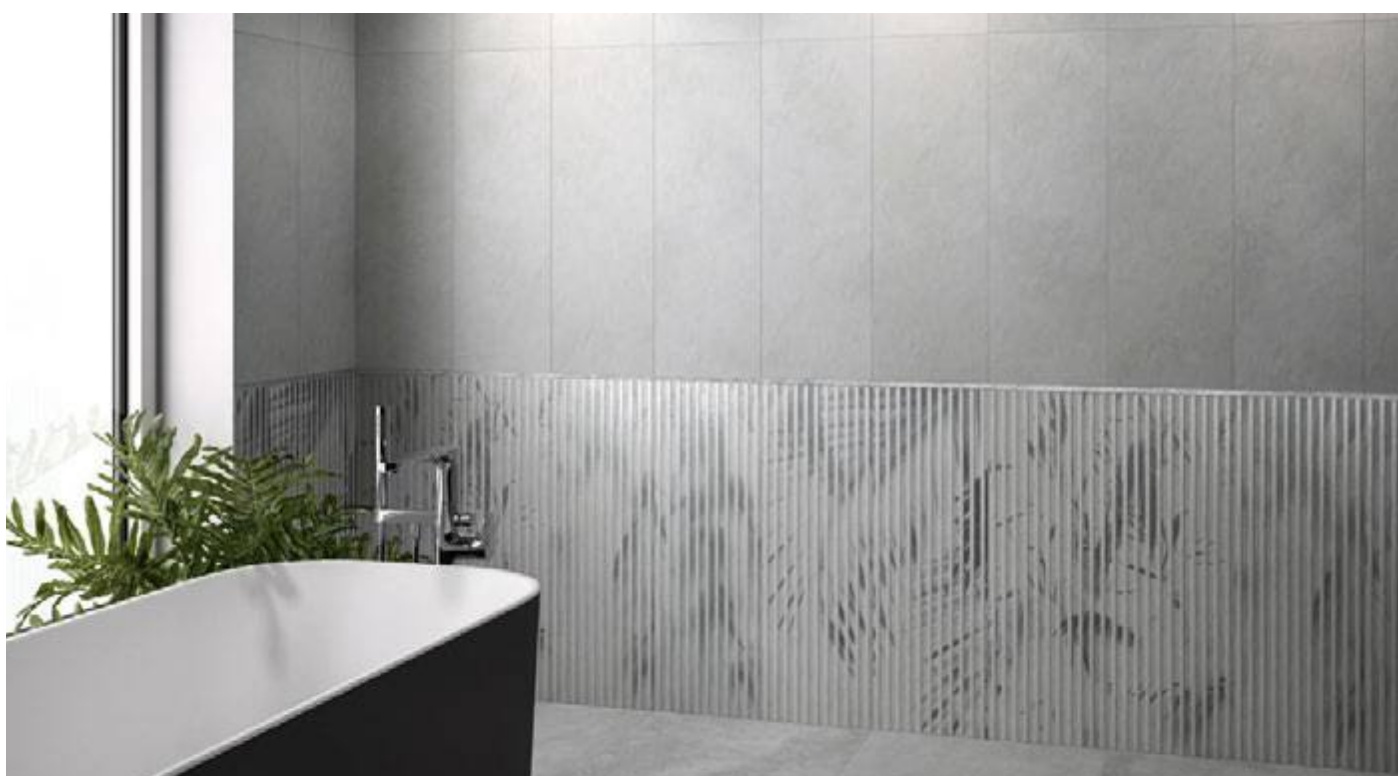

Zwei Optiken in einem Design:  
Je nach Betrachtungswinkel und Beleuchtung kommt das graphisch-florale Muster stärker oder schwächer zum Vorschein. OMBRA ist eine elegante Serie mit glamourösem Touch, zu dem neben dem Design die Farbe Silber mit schönen Glanzpunkten beiträgt.

*Two looks in one design: The graphic floral pattern comes more or less to the fore, depending on the incident light and the angle at which it is viewed. OMBRA is an elegant range with a glamorous touch that stems both from the design and from the silver colour which adds attractive highlights.*



*Illusions in the play of light and shade*



Bodenfliesen · Floor tiles: METALYN iron | Wandfliesen · Wall tiles: OMBRA white

Ein Raum, der durch Einfachheit besticht und doch das Bad in Szene setzt. Die Fliesenserie OMBRA erzeugt eine heitere Stimmung, die für Wohlbefinden sorgt.



*A room of alluring simplicity. The OMBRA tile range creates an upbeat mood that is conducive to well-being.*

**NOCTURNE***Bleibende Werte für  
die Moderne*

Marmoroberflächen faszinierten zu allen Zeiten. Das besondere des Materials ist seine durchscheinend zarte Wirkung und die feinen Äderungen, die ihm eine plastische Tiefenwirkung geben. Mit NOCTURNE ist es gelungen, diese feine Ästhetik auf keramische Fliesen zu bannen.

*Marble surfaces have a timeless allure. What sets this material apart is its delicate translucent effect and the fine veining that lends it a three-dimensional depth effect. NOCTURNE captures this fine aesthetic on ceramic tiles.*



*Timeless values for the modern age*

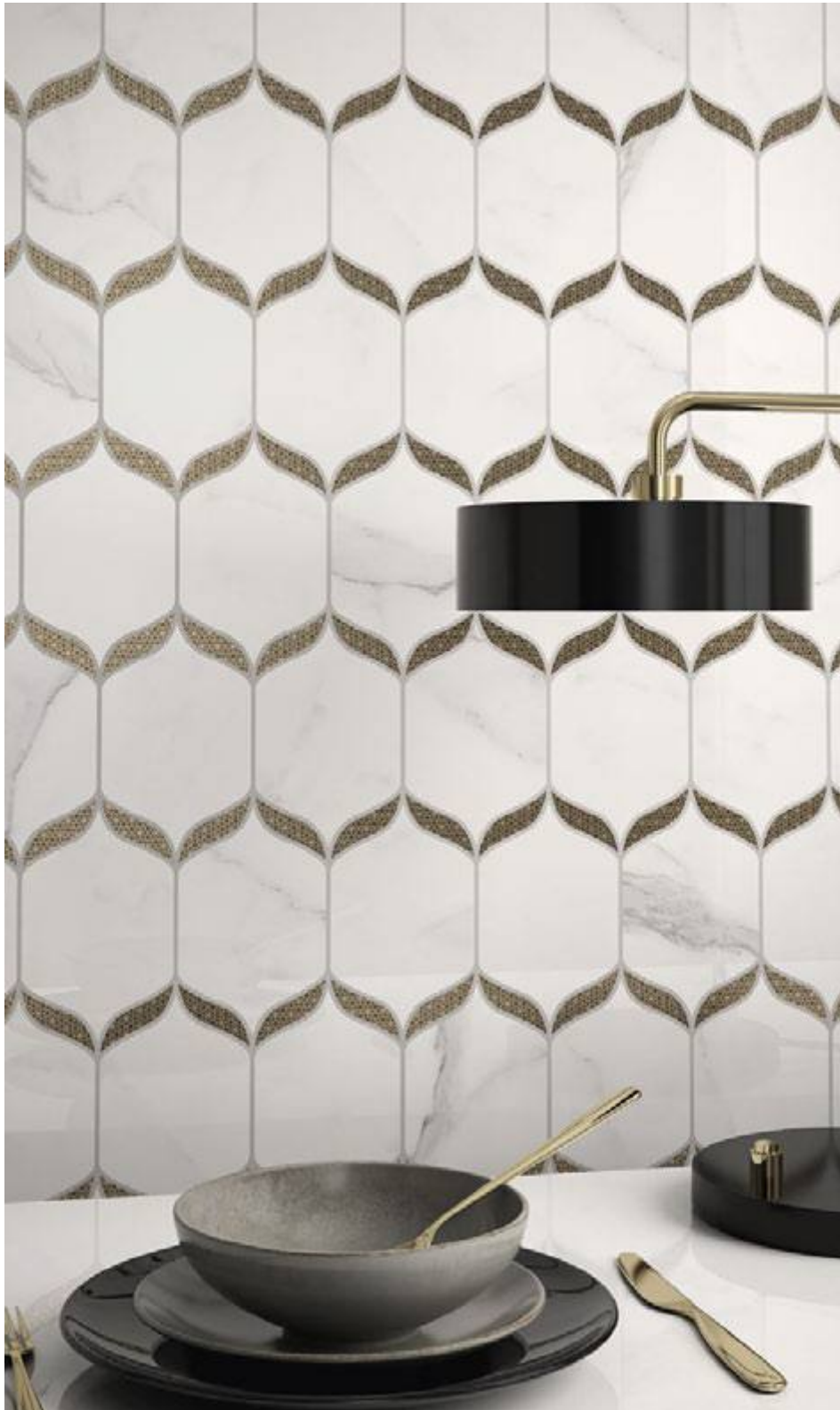

Für die Klassik steht eine Formensprache, die sich durch gleichmäßige Proportionen und ornamentale Formen auszeichnet.

*The classic style is informed by a design idiom defined by even proportions and ornamental forms.*

Die ungewöhnliche Kombination von Dekor und Grundfliese zeigt NOCTURNE von einer kreativen, modernen Seite.

*The unusual combination of décor and floor tile shows NOCTURNE in a creative, modern light.*



Bodenfliesen, Dekor · Floor tiles, Décor: NOCTURNE white | Wandfliesen, Dekor · Wall tiles, Décor: NOCTURNE black



## Produktübersichten / Overview of Products

- 40 ALTA
- 42 DAYTONA
- 44 FALCONAR
- 46 METALYN
- 48 NOCTURNE
- 50 OMBRA
- 51 ROCKY.ART
- 54 Technische Besonderheit / Special features

the Art of  
Simplicity

**Grundfliesen aus Steingut (nur für die Wand geeignet)**  
**Nonvitreous basic tiles (suitable for walls only)**



Art. 1333 · 33 x 99 cm  
 silver white



RZ00

Art. 1581 · 30 x 60 cm  
 silver white



RZ00

**Grundfliesen aus Feinsteinzeug (für Wand und Boden geeignet)**  
**Porcelain stoneware basic tiles (suitable for walls and floors)**



Art. 2570 · 60 x 60 cm  
 ivory

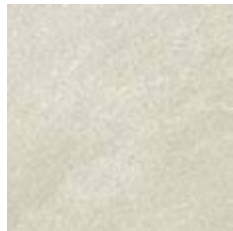

RZ10

honey

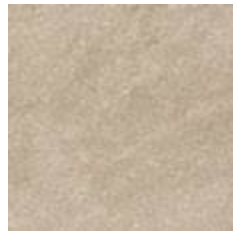

RZ20

silver



RZ60

ash

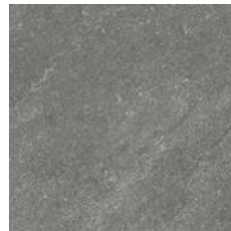

RZ90

Art. 2572  
 30 x 60 cm

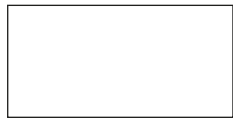

RZ10 · RZ20 · RZ60 · RZ90

Art. 2872  
 7,5 x 60 cm  
 Sockel  
 Skirting

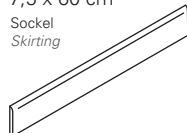

RZ10 · RZ20 · RZ60 · RZ90

Art. 2812  
 80 x 80 cm

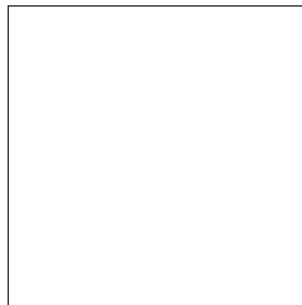

RZ10 · RZ20 · RZ60 · RZ90

Art. 2136  
 30 x 60 cm

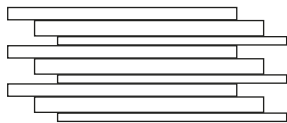

RZ10 · RZ20 · RZ60 · RZ90

Art. 2013  
 7,5 x 7,5 cm

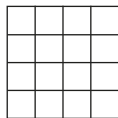

RZ10 · RZ20 · RZ60 · RZ90

Art. 2137 · 15 x 60 cm  
 ivory



RZ10

honey



RZ20

silver



RZ60

ash



RZ90

# ALTA

## Variationsvielfalt | *Shade variation*



ivory



honey



silver

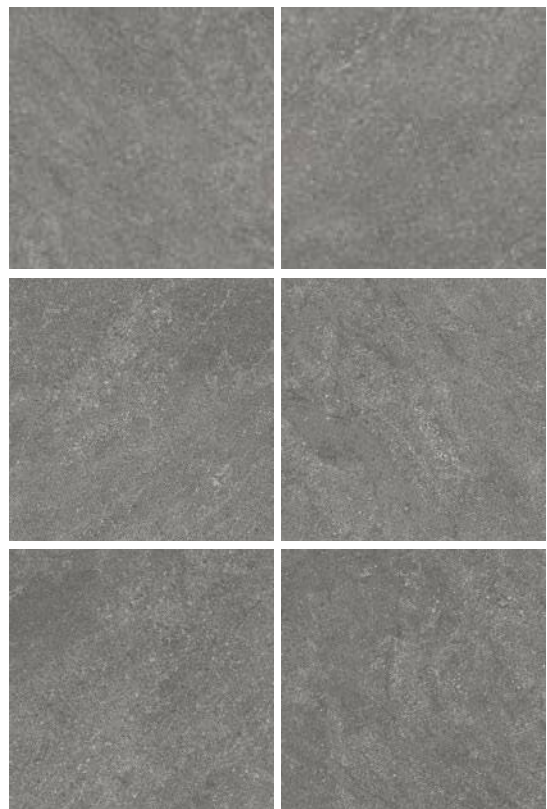

ash



# DAYTONA

**Grundfliesen aus Feinsteinzeug (für Wand und Boden geeignet)**  
*Porcelain stoneware basic tiles (suitable for walls and floors)*

Art. 2341 · 30 x 60 cm

creme



BP20 2  
 R10 B

greige



BP70 2  
 R10 B

grey



BP60 2  
 R10 B

dark grey



BP90 2  
 R10 B



**Grundfliesen aus glasiertem Feinsteinzeug (für Wand und Boden geeignet)**  
*Glazed porcelain stoneware basic tiles (suitable for walls and floors)*

Art. 2706 · 5 x 5 cm

creme



BP20  
 4 R10 B

greige



BP70  
 3 R10 B

grey



BP60  
 4 R10 B

dark grey

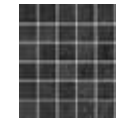

BP90  
 2 R10 B





# DAYTONA

Variationsvielfalt | *Shade variation*

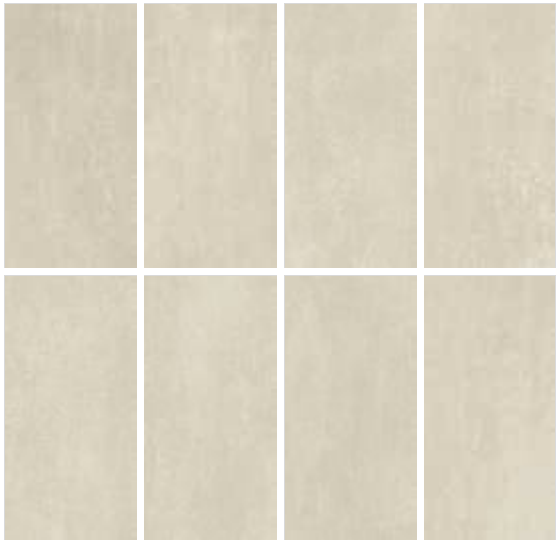

creme

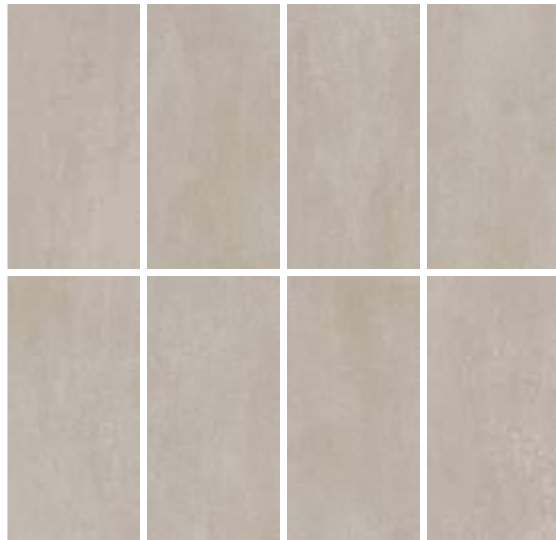

greige

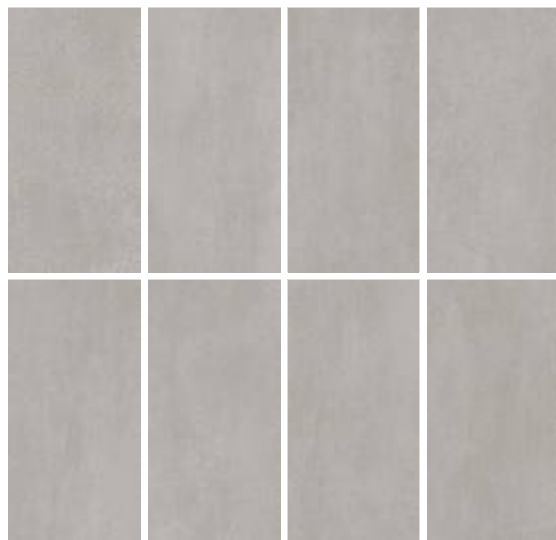

grey

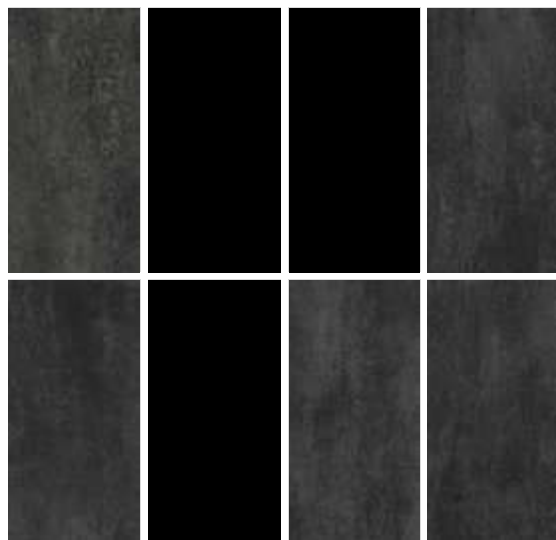

dark grey



**Grundfliesen aus Steingut (nur für die Wand geeignet)**  
*Nonvitreous basic tiles (suitable for walls only)*



Art. 1440 · 40 x 120 cm  
pearl



AB00



Art. 1581 · 30 x 60 cm  
pearl



AB00



**Grundfliesen aus Feinsteinzeug (für Wand und Boden geeignet)**  
*Porcelain stoneware basic tiles (suitable for walls and floors)*



Art. 2660 · 60 x 60 cm  
clay



AB70



opal grey



AB60



carbon



AB90



Art. 2730  
60 x 120 cm

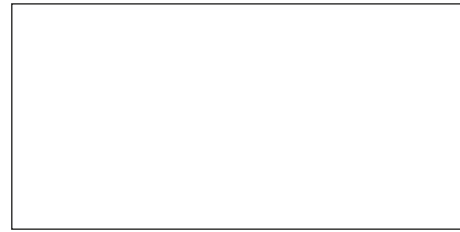

AB70 · AB60 · AB90



Art. 2394  
30 x 60 cm



AB70 · AB60 · AB90



Art. 2372  
30 x 30 cm

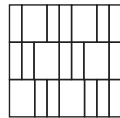

AB70 · AB60 · AB90



Art. 2013  
7,5 x 7,5 cm

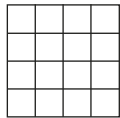

AB70 · AB60 · AB90



Art. 2872  
7,5 x 60 cm  
Sockel  
Skirting

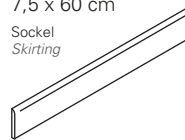

AB70 · AB60 · AB90



**Dekorfliesen aus glasiertem Feinsteinzeug (für Wand und Boden geeignet)**  
*Porcelain glazed stoneware basic tiles (suitable for walls and floors)*



Art. 2730 · 60 x 120 cm  
clay



AB75



opal grey



AB65



carbon

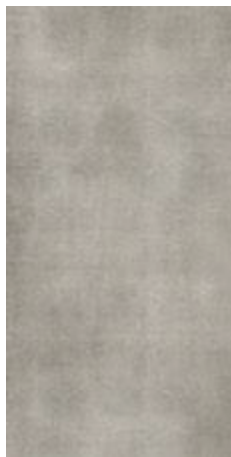

AB95



Art. 2356 · 30 x 120 cm  
clay



AB75



opal grey



AB65



carbon



AB95



# FALCONAR

Variationsvielfalt | *Shade variation*

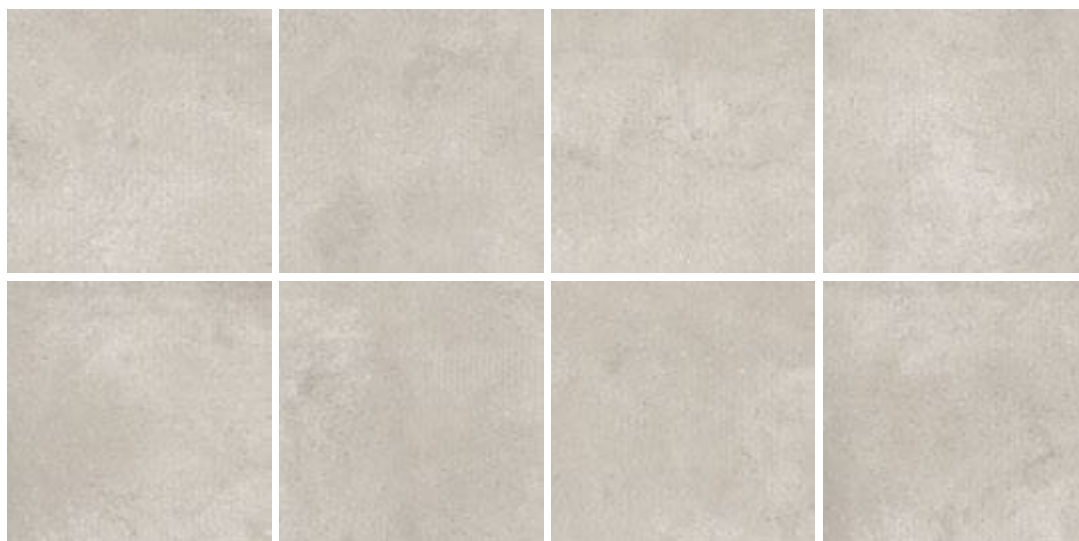

clay



opal grey

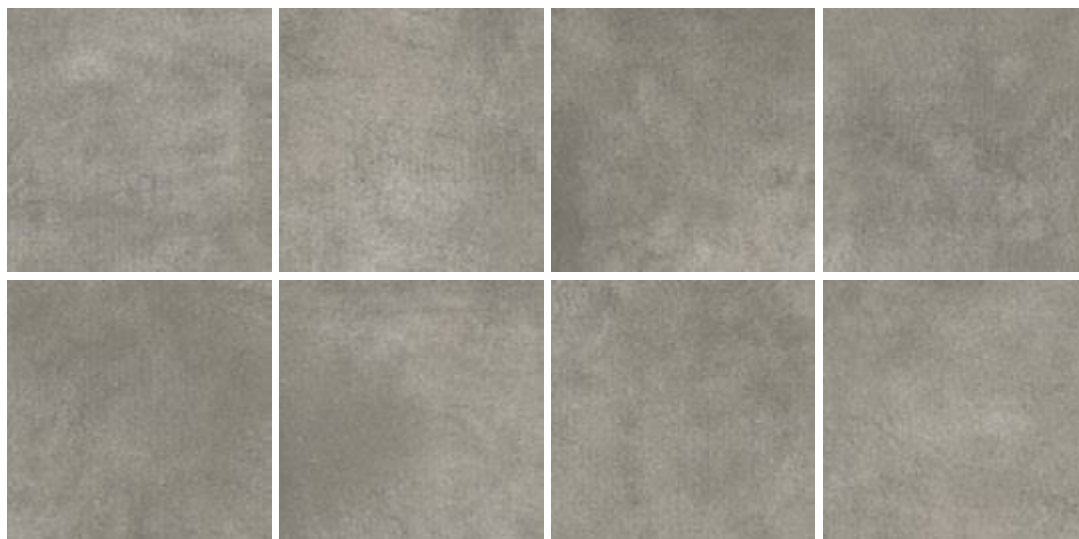

carbon



# METALYN

**Grundfliesen aus Feinsteinzeug (für Wand und Boden geeignet)**  
*Porcelain stoneware basic tiles (suitable for walls and floors)*



Art. 2730 · 60 x 120 cm  
silver



BM06 BM10   
 R10

iron



BM40 BM60   
 R10

pearl



BM10 BM70   
 R10

steel



BM60 BM61   
 R10

bronze



BM70   
 R10

oxide



BM61   
 R10

Art. 2810  
80 x 80 cm

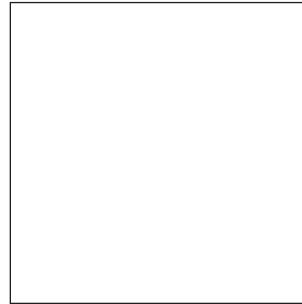

BM06 · BM10 · BM70  
 BM40 · BM60 · BM61  
 R10

Art. 2660  
60 x 60 cm

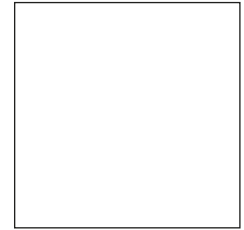

BM06 · BM10 · BM70  
 BM40 · BM60 · BM61  
 R10

Art. 2394  
30 x 60 cm

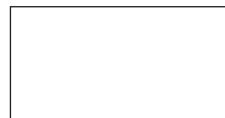

BM06 · BM10 · BM70  
 BM40 · BM60 · BM61  
 R10

Art. 2024  
1,6 x 60 cm

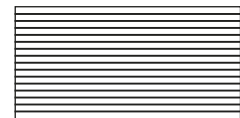

BM06 · BM10 · BM70  
 BM40 · BM60 · BM61  
 R10

Art. 2013  
7,5 x 7,5 cm

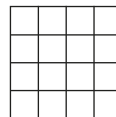

BM06 · BM10 · BM70  
 BM40 · BM60 · BM61  
 R10 B

Art. 2872  
7,5 x 60 cm

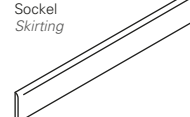

BM06 · BM10 · BM70  
 BM40 · BM60 · BM61  
 R10

**Dekorfliesen aus glasiertem Feinsteinzeug (für Wand und Boden geeignet)**  
*Porcelain glazed stoneware basic tiles (suitable for walls and floors)*

Art. 2730 · 60 x 120 cm  
multicolor



BM65 R10

Art. 2356 · 30 x 120 cm  
multicolor



BM65 R10

Zeichenschlüssel: Seite 58  
 Signs & symbols: page 58

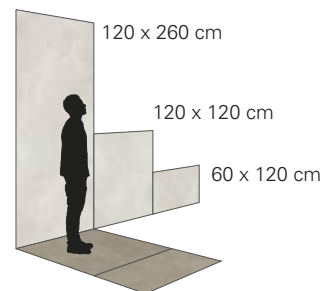

OPTIMA: auch in den Formaten 60 x 120, 120 x 120 und 120 x 260 cm in 6 mm erhältlich.  
 OPTIMA: also available in the formats 60 x 120, 120 x 120 and 120 x 260 cm in 6 mm thickness.



# METALYN

## Variationsvielfalt | *Shade variation*

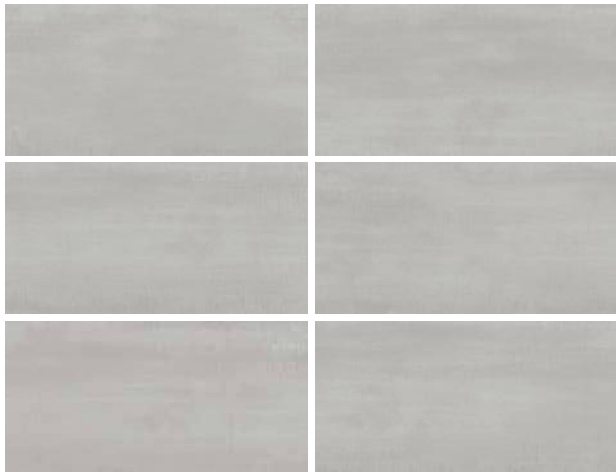

silver



iron

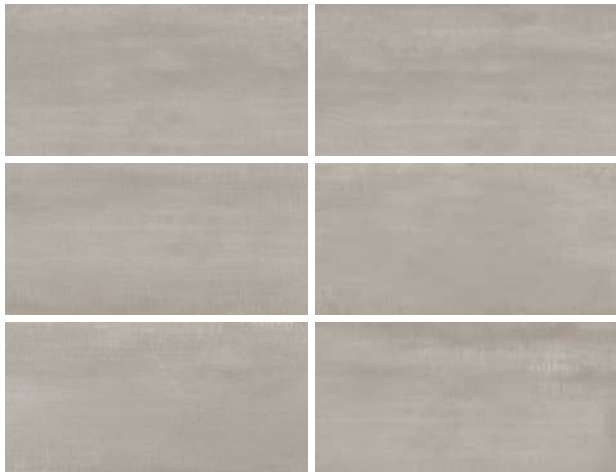

pearl

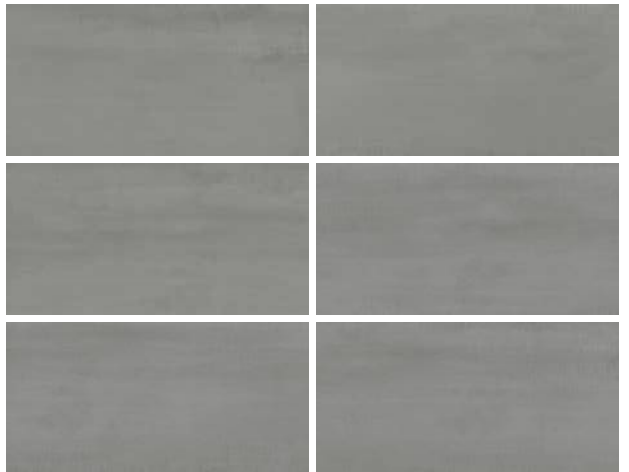

steel

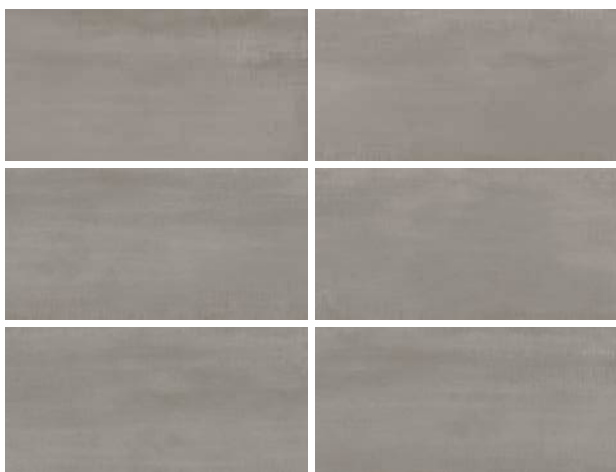

bronze

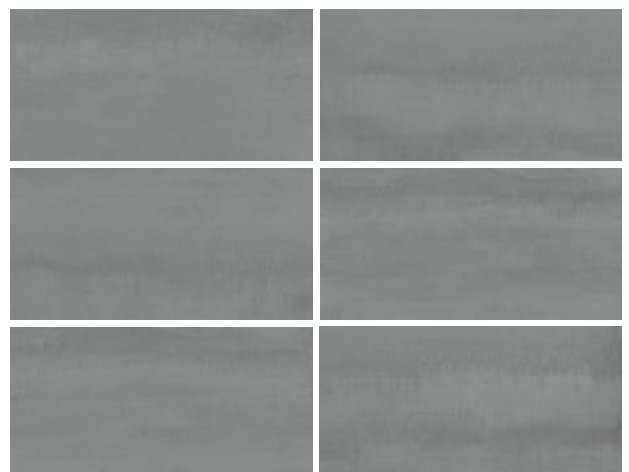

oxide



# NOCTURNE *Excellence*

**Grundfliesen aus glasiertem Feinsteinzeug (für Wand und Boden geeignet)**  
*Glazed porcelain stoneware basic tiles (suitable for walls and floors)*

Art. 2660 · 60 x 60 cm  
 white



ZN1L  
**3**  
 ZN1P  
**3**

white gold



ZN2L  
**3**  
 ZN2P  
**3**

black



ZN9L  
**2**  
 ZN9P  
**2**

Art. 2730  
 60 x 120 cm



ZN1L · ZN2L  
**3**  
 ZN9L  
**2**  
 ZN1P · ZN2P  
**3**  
 ZN9P  
**2**

Art. 2044 · 60 x 60 cm  
 white flower



ZN1P  
**2**

black flower



ZN9P  
**2**

Art. 2045 · 25 x 30 cm  
 honeycomb gold honeycomb black



ZN1P\*  
**▲**



ZN9P  
**2**

Art. 2043 · 20 x 23 cm  
 white



ZN1P  
**2**

multicolor



ZN8P\*  
**▲**

black



ZN9P  
**2**

Art. 2041 · 21 x 21 cm  
 gold



ZN2P\*  
**▲**

silver

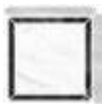

ZN8P\*  
**▲**

\* = nur für die Wand geeignet · rough-polished  
 L = geläpft/anpoliert · suitable for walls only  
 P = poliert · polished

# NOCTURNE

Variationsvielfalt | *Shade variation*

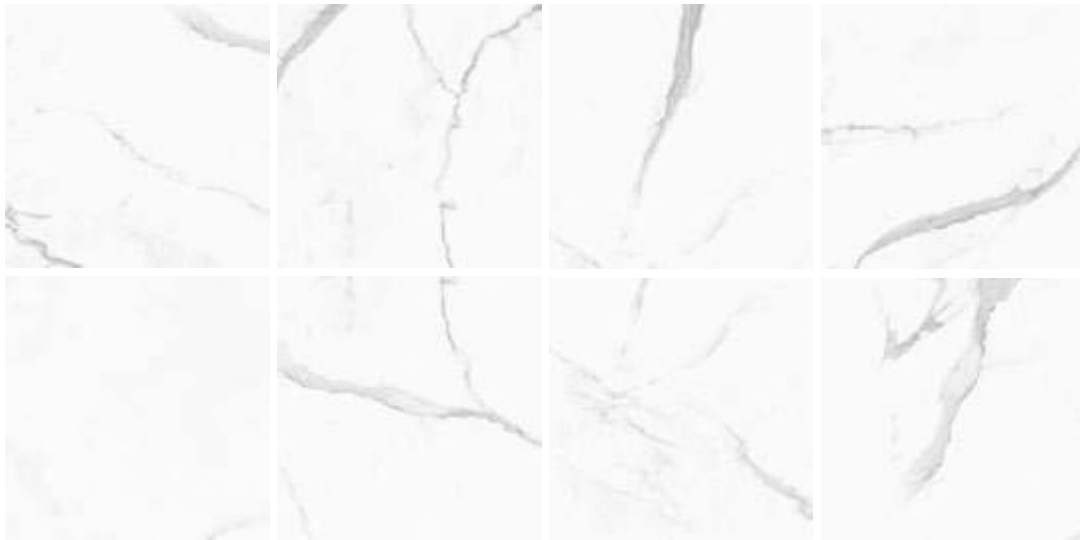

white

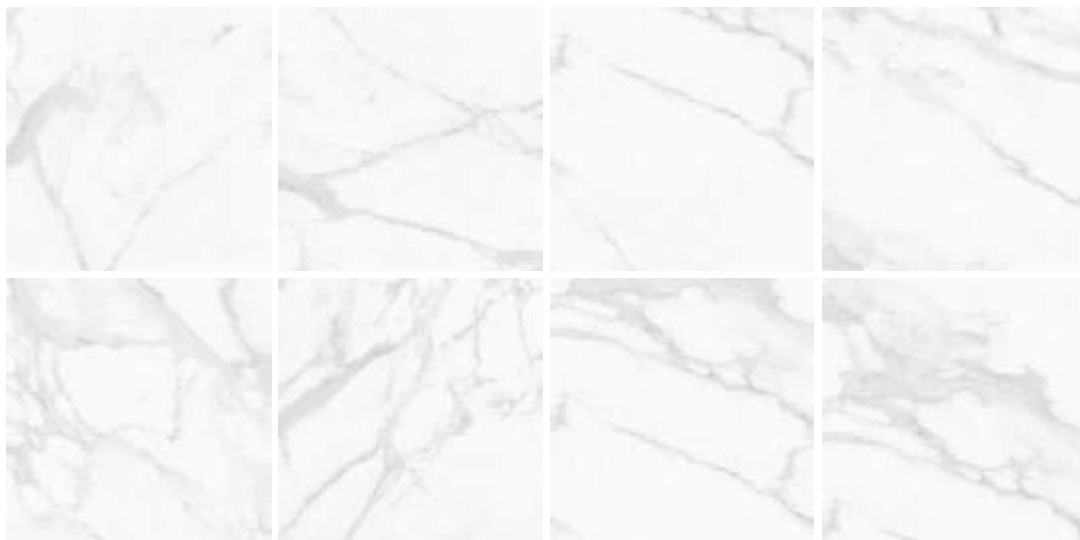

white gold

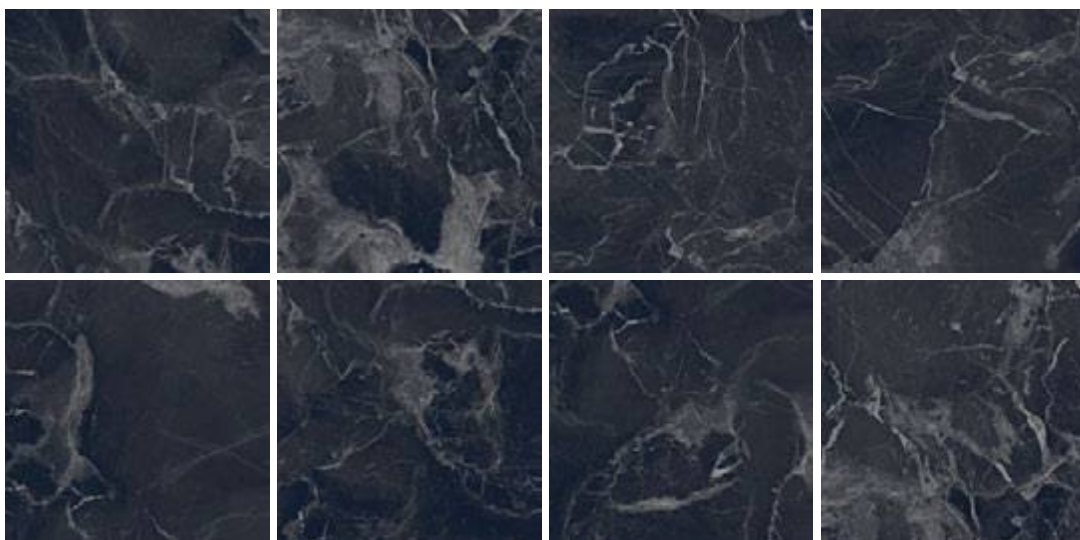

black



# OMBRA *Excellence*

**Grundfliesen und Dekorfliesen aus Steingut (nur für die Wand geeignet)**  
**Nonvitreous basic tiles and décor tiles (suitable for walls only)**



Art. 1310 · 30 x 90 cm

white



IA01



grey

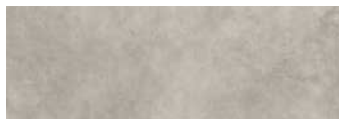

IA03



IA11

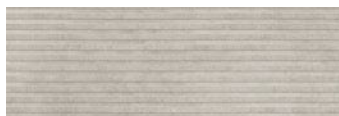

IA31



IA12



IA32



Art. 1070 · 1 x 90 cm

silver



IA00



Passende Bodenfliesen · Recommended floor tiles:  
 METALYN



# ROCKY.ART

**Grundfliesen und Dekorfliesen aus Steingut (nur für die Wand geeignet)**  
*Nonvitreous basic tiles and décor tiles (suitable for walls only)*

**PowderTouch**  
*Steingut · Nonvitreous*

**ceramicplus**  
 Villeroy & Boch

Art. 1333 · 33 x 99 cm  
 cotton

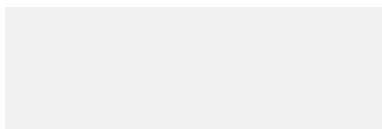

CB10



snow

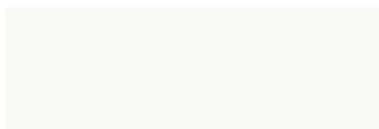

CB00



Art. 1333 · 33 x 99 cm  
 magical blue

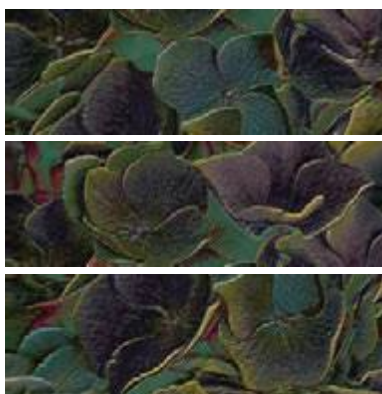

CB66



3 Stück im Set  
 3 piece set

Art. 1581 · 30 x 60 cm  
 cotton

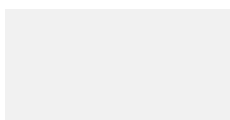

CB10



snow

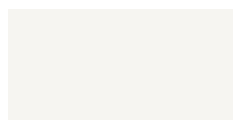

CB00



Art. 1260 · 20 x 60 cm  
 cotton

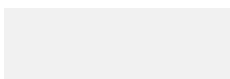

CB10



fango



CB70



snow

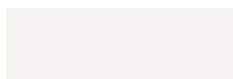

CB00



pebble



CB60



cotton



CB15



fango



CB75



snow



CB05



pebble



CB65



# ROCKY.ART

**Grundfliesen aus Feinsteinzeug (für Wand und Boden geeignet)**  
*Porcelain stoneware basic tiles (suitable for walls and floors)*

**vilbostone**plus

**vilbostone**  
*Feinsteinzeug · Porcelain stoneware*

Art. 2376 · 60 x 60 cm  
 white sand



CB10  
 ✱ ✱ ✱ R10

fango

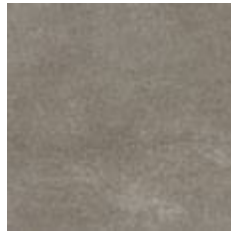

CB70  
 ✱ ✱ ✱ R10

pebble

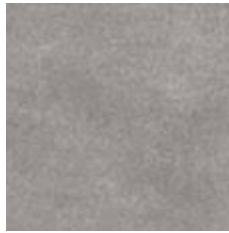

CB60  
 ✱ ✱ ✱ R10

basalt

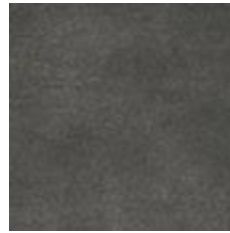

CB90  
 ✱ ✱ ✱ R10

Art. 2839  
 80 x 80 cm

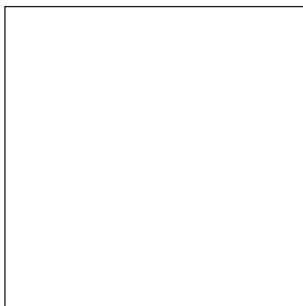

CB10 · CB70  
 CB60 · CB90  
 ✱ ✱ ✱ R10

Art. 2825  
 40 x 80 cm

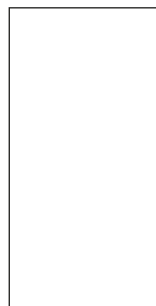

CB10 · CB70  
 CB60 · CB90  
 ✱ ✱ ✱ R10

Art. 2377  
 30 x 60 cm



CB10 · CB70  
 CB60 · CB90  
 ✱ ✱ ✱ R10

Art. 2735  
 45 x 45 cm



CB10 · CB70  
 CB60 · CB90  
 ✱ ✱ R10

Art. 2013  
 7,5 x 7,5 cm

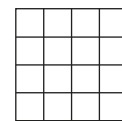

CB10 · CB70  
 CB60 · CB90  
 ✱ ✱ ✱ R10 ✱ B

Art. 2379  
 30 x 30 cm

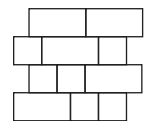

CB10 · CB70  
 CB60 · CB90  
 ✱ ✱ ✱ R10

Art. 2872  
 7,5 x 60 cm

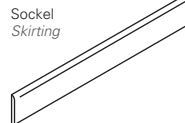

Socket  
 Skirting  
 CB10 · CB70  
 CB60 · CB90  
 ✱ ✱

Art. 2717  
 8 x 45 cm



Socket  
 Skirting  
 CB10 · CB70  
 CB60 · CB90  
 ✱

**Dekorfliesen aus glasiertem Feinsteinzeug (für Wand und Boden geeignet)**  
*Porcelain glazed stoneware basic tiles (suitable for walls and floors)*

Art. 2730 · 60 x 120 cm  
 limelight



CB65  
 ✱ ✱ ✱ 4 ✱ R10

Art. 2356 · 30 x 120 cm  
 limelight



CB65  
 ✱ ✱ ✱ 4 ✱ R10

**vilbostone**  
*Feinsteinzeug · Porcelain stoneware*

**vilbotouch**

# ROCKY.ART

Variationsvielfalt | *Shade variation*

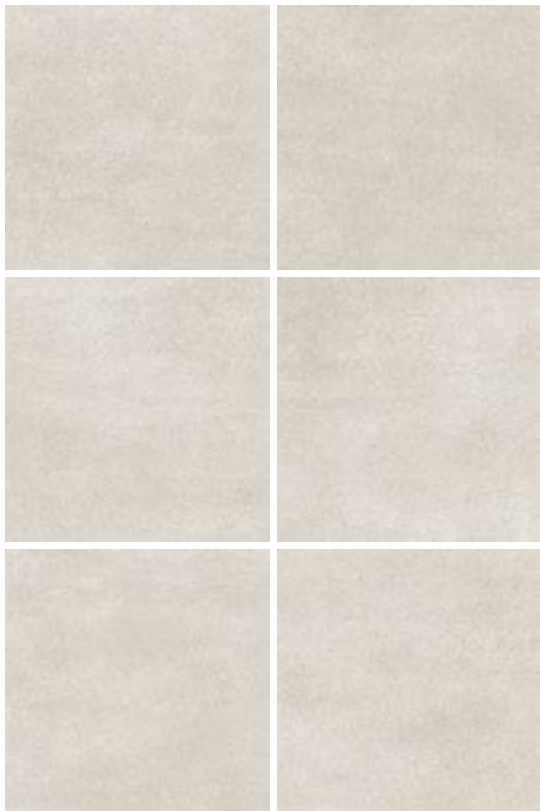

white sand

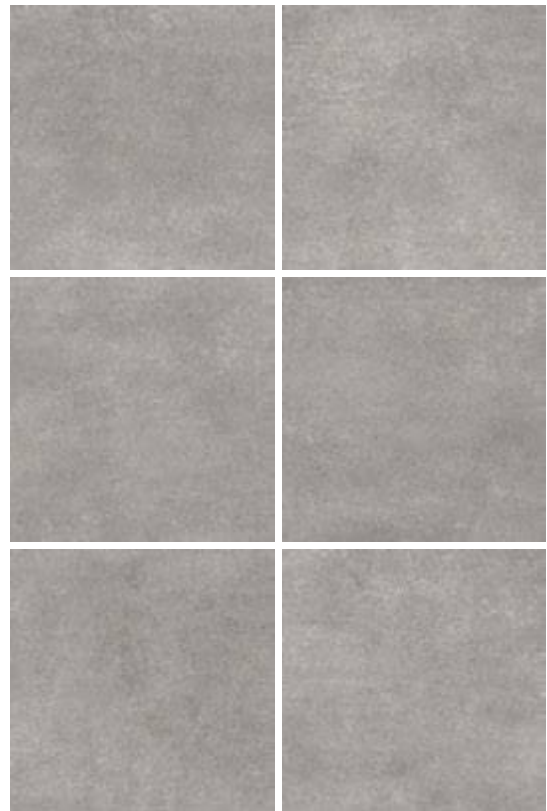

pebble

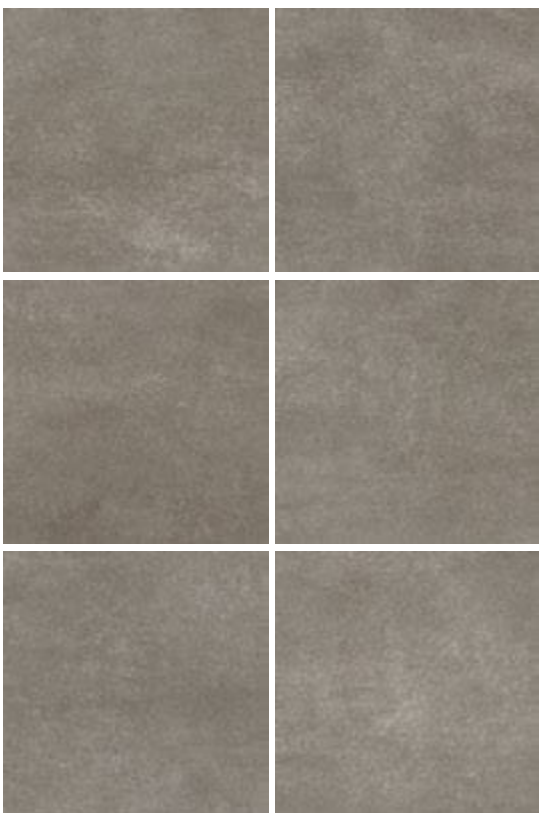

fango

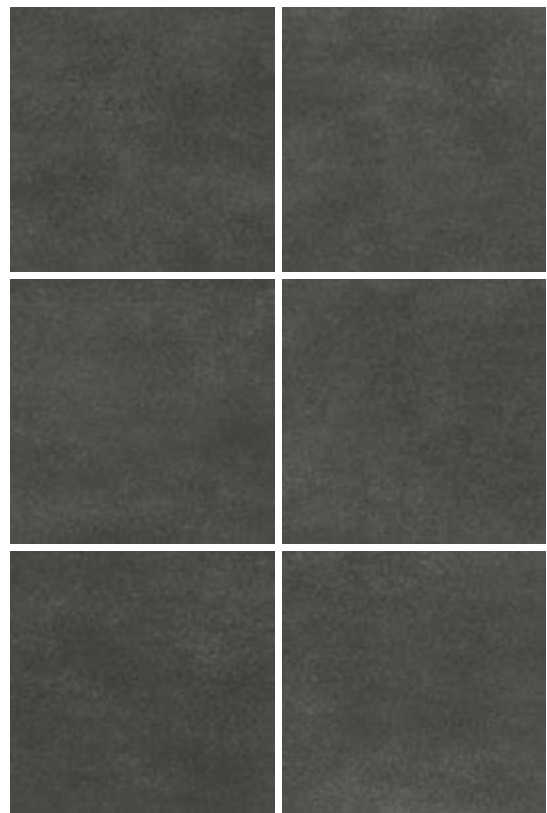

basalt



# *Für die Zukunft der Fliesen*

*Tiles for the future*



Handeln im Einklang mit der Natur steht bei der V&B Fliesen GmbH klar im Vordergrund. Höchste Ansprüche an Qualität, Effizienz und Umweltverträglichkeit ist die Basis unseres täglichen Schaffens. Und nur, wenn wir unsere Umwelt mit Respekt behandeln, können wir auch für zukünftige Generationen das erhalten, was wir lieben. Deshalb ist es uns wichtig, Pionierarbeit zu leisten. Und zwar nicht nur in Sachen Fliesentechnologie, sondern vor allem auch im Bereich Umweltschutz!

*Acting in harmony with Nature is a clear priority for V&B Fliesen GmbH. Our daily business is based on extremely high standards where quality, efficiency and environmental friendliness are concerned. And we can only preserve what we love for future generations by treating our environment with respect. That's why we think it's important to be on the cutting edge. Not just with regard to tile technology, but above all in terms of environmental protection!*



### Die EMAS – Validierung

Dazu gehört, dass wir uns freiwillig und als erster deutscher Fliesenhersteller den hohen Anforderungen der EMAS-Richtlinien der EU unterzogen haben. Bereits zum dritten Mal in Folge hat die V&B Fliesen GmbH im Jahr 2019 durch einen externen Umweltgutachter für weitere drei Jahre die Validierung erhalten. Im Einklang mit diesen Richtlinien sind wir stets bestrebt, unsere Umwelleistungen durch immer neue Maßnahmen im Bereich Energie- oder Ressourceneffizienz zu verbessern. Auch unsere Mitarbeiter erfüllen die Anforderungen in vorbildlicher Weise und unterziehen sich diesem Prozess und dessen Audits.

#### **EMAS validation**

*One aspect of this is that we have voluntarily become the first tile manufacturer in Germany to comply with the stringent requirements of the EU EMAS Directive. V&B Fliesen GmbH was validated for another three years by an external environmental expert again in 2019, for the third time in a row.*

*In accordance with the directive we aim to improve our environmental performance all the time by constantly implementing new measures to help us use energy and resources more efficiently. Our employees also fulfil these requirements in an exemplary manner, in full compliance with the process and its auditing.*



### Ressourcenschonende, umweltbewusste Produktion

Unsere Fliesen sind mit dem EPD-Label des IBU (Institut für Bauen und Umwelt e.V.) ausgezeichnet. EPD, Environmental Product Declaration, steht für die Bereitstellung relevanter, überprüfbarer und vergleichbarer Informationen zu Umweltbelastungen von Produkten. Diese Zertifizierung ermöglicht Architekten und Planungsbüros unsere Produkte in allen Objekten einzusetzen, die nach BREEAM, LEED, DGNB oder vergleichbaren internationalen Deklarationen für nachhaltiges Bauen eingestuft sind.

#### ***Ecological, environmentally friendly production***

*Our tiles have been awarded the Environmental Product Declaration (EPD) label by the IBU (Institut für Bauen und Umwelt e.V.). The Environmental Product Declaration provides relevant, verifiable and comparable information on the environmental impact of products. This certification allows architects and planners to utilise our products in all properties that have been certified as satisfying the BREEAM, LEED, DGNB or other comparable international requirements for sustainable building.*



## ceramicplus

Villeroy & Boch

Unsere Wandfliesen aus Steingut sind werkseitig mit ceramicplus ausgestattet. Mit dieser pflegeleichten Oberfläche brauchen unsere Fliesen wesentlich weniger Pflege. Zur Reinigung genügen oft nur Wasser und ein Tuch, aggressive Reiniger werden überflüssig.

*The ceramicplus finish is applied to our nonvitreous wall tiles at the factory. Our tiles thus require much less care. Often, the only cleaning materials that are required are water and a cloth; aggressive cleaning agents are redundant.*



## PowderTouch

Steingut · Nonvitreous

Innovative Matt-Finish-Glasur für Fliesen aus Steingut. Die Glasur verleiht den Wandfliesen eine ultramatte Oberflächenanmutung mit einer pudrig-sanften Haptik und lässt die Farben edel und modern wirken.

*Innovative matt-finish glaze for nonvitreous tiles. This glaze gives wall tiles an ultra-matt surface finish with a powdery soft feel and makes colours look exquisite and modern.*



## concept<sup>3</sup>

Die concept<sup>3</sup>-Serien sind durchdachte Wand- und Bodenkonzepte, bei denen alles bis ins kleinste Detail zusammenpasst: Die Farben, Formate, Designs und Dekorationen der Wandfliesen aus Steingut und hochwertigen Bodenfliesen aus vilbostone Feinsteinzeug sind so perfekt aufeinander abgestimmt, dass sie ästhetische Raumgestaltungen wie aus einem Guss ermöglichen – ganz individuell und dabei immer stilsicher.

*The concept<sup>3</sup> ranges are sophisticated wall and floor concepts in which everything matches, down to the smallest detail: the colours, formats, designs and decorations of the nonvitreous wall tiles and of the high-quality floor tiles made of vilbostone porcelain stoneware match up so perfectly that they permit seamless aesthetic interior designs – very individual and always stylish.*

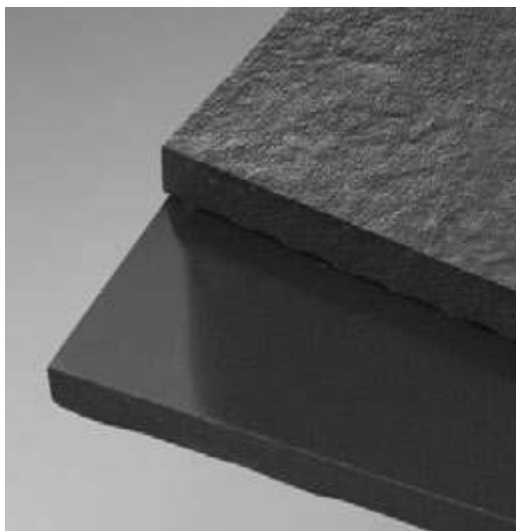

## vilbostone

Feinsteinzeug · Porcelain stoneware

vilbostone Feinsteinzeug ermöglicht eine Vielzahl unterschiedlicher Oberflächen-Designs mit außergewöhnlichen Farb- und Glanzeffekten. Erhältlich ist vilbostone Feinsteinzeug als unglasiertes und glasiertes Material mit matten, polierten, anpolierten sowie reliefierten Oberflächen und mit unterschiedlichen Rutschhemmungen.

*vilbostone porcelain stoneware permits a wealth of different surface designs featuring unusual colour and sheen effects. vilbostone porcelain stoneware is available both glazed and unglazed, with a matt, polished, rough-polished or relief surface finish and in various classes of slip resistance.*

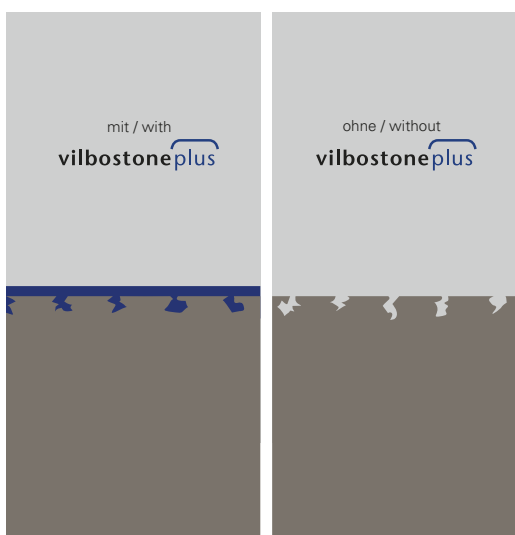

## vilbostoneplus

Das unglasierte vilbostone Feinsteinzeug ist in matter und anpolierter Ausführung mit der Oberflächenversiegelung vilbostone**plus** ausgestattet, das die Fliesen unempfindlich gegen Schmutz und Flecken macht. Während des Herstellungsprozesses der Fliesen wird die Struktur ihrer Oberflächen so versiegelt, dass die Fleck- und Schmutzbeständigkeit weiter zunimmt und eine Nachbehandlung mit Imprägniermitteln nicht mehr erforderlich ist.

*Unglazed vilbostone porcelain stoneware with a matt or rough-polished surface finish have the vilbostone**plus** seal, which renders the tiles particularly resistant to dirt and stains. During the manufacturing process, the structure of the tile surface is sealed in order to further increase the tiles' resistance to staining and dirt, as a result of which subsequent treatment with impregnating agents is no longer necessary.*



## vilbotouch













vilbotouch, ein neues weich anmutendes Oberflächenfinish, geschaffen als Symbiose aus Ästhetik und Technik. Die mikroskopisch feine Struktur sorgt dafür, dass die Fliesen die Trittsicherheitsklasse R10 erfüllen und sich gleichzeitig durch besondere Pflegeleichtigkeit auszeichnen.

*vilbotouch a new surface finish with a soft look, created as a symbiosis of aesthetic appeal and technical functionality. The microscopically fine structure ensures that the tiles comply with slip resistance class R10 while also providing for an easy-care finish.*

## Zeichenschlüssel

### 1 2 3 4 5 Abriebgruppe (DIN EN ISO 10545-7)













Die Abriebgruppe beschreibt die Verschleißeigenschaft von Fliesen aus glasiertem Steinzeug. Es werden 5 Abriebgruppen unterschieden: von 1 (sehr leichte Beanspruchung) bis 5 (starke Beanspruchung)

-  Rutschhemmung im gewerblichen Bereich
-  Rutschhemmung im Barfußbereich
-  Frostbeständig nach DIN EN ISO 10545-12
-  Rektifiziert
-  Edelmetallaufgabe. Kratzempfindliches Dekor. Reinigung nur mit Wasser und Geschirrspülmittel. Verfugung nur mit geeigneten, fein aufgemahlten, quarzarmen Fugenfüllern.
-  Glasauflage, Craquelébildung möglich (feine Haarrisse in der Glasur)
-  Fliesenstärke 6 mm
-  **ceramicplus**
-  **vilbostoneplus** Oberflächenversiegelung
-  **vilbotouch** microfeine rutschhemmende Oberfläche
-  **PowderTouch** Matte, pudrige Premiumglasur
-  **concept<sup>3</sup>** Komplettes Wand- und Bodenkonzept
-  **1 2 3 4** Variationsvielfalt

## Signs and symbols

### 1 2 3 4 5 Wear-resistance group (DIN EN ISO 10545-7)

The wear-resistance group defines the wearing properties of tiles in glazed vitreous. A distinction is made between 5 wear-resistance groups, from 1 (suitable for minimal stress) to 5 (suitable for high levels)

-  *Anti-slip in workshop areas*
-  *Anti-slip in barefoot areas*
-  *Frostproof in acc. with DIN EN ISO 10545-12*
-  *Rectified*
-  *Precious metal-plated. Not scratchproof. Clean with water or dish washing liquid only. Use only a suitable, fine-grain mortar with low quartz content for jointing.*
-  *Glass-plated. Hairline cracks in the glaze may develop.*
-  *Tile thickness 6 mm*
-  **ceramicplus**
-  **vilbostoneplus** *Surface seal*
-  **vilbotouch** *Micro-fine slip-resistant surface finish*
-  **PowderTouch** *Matt, powdery premium glaze*
-  **concept<sup>3</sup>** *Complete wall and floor concept*
-  **1 2 3 4** *Shade variation*





Villeroy & Boch  
1748

*Loving &  
Living Tiles*

# Inhalt

## *Contents*

URBAN JUNGLE	6
ATLANTA	12
WORKSHOP	18
LIGHTPLAY	24
METRO FLAIR	28
BELLAGIO	34
GATEWAY	38
OAK PARK	42
ABERDEEN	46
Produktübersichten <i>Overview of Products</i>	51

Die Welt ist voller Inspirationen! Wer etwas Neues schaffen möchte, muss nur offen sein für das, was um ihn herum geschieht - und seine Eindrücke kreativ weiterentwickeln. Die wunderbarsten Formen, Oberflächen und Farben findet man in der Natur. Und Kunst, Mode und Architektur bilden ab, wie der Mensch seine Lebenswelt formt.

**Die Welt ist voller Inspirationen!**  
*The world is full of inspiration!*

*The world is full of inspiration! If you want to create something new, you just have to be open to what is happening all around you - and then develop these impressions in an original way. The most wonderful shapes, surfaces and colours are to be found in nature. And art, fashion and architecture reflect how people shape their world.*

# Loving & Living Tiles

In der Fliesenkollektion 2019 kommen beide Aspekte zusammen: Die neuen Designs, Dekore, Oberflächen und Formate stehen für die große Vielfalt, die das moderne Leben ausmacht, und interpretieren die Themen Beton, Naturstein, Holz und Farbe in Keramik. Das Ergebnis sind durchdachte Fliesenserien, die begeistern und inspirieren, Räume zu gestalten, in denen man gerne lebt - ganz individuell und voller Emotionen.

Denn Fliesen von Villeroy & Boch sind mehr als schöne Wand- und Bodenbeläge. In jedem einzelnen Schritt, vom Design über die Produktion bis hin zur Vermarktung, stecken ganz viel Herzblut und Liebe. Das kann man spüren, und genau darum lautet das Credo: Loving & Living Tiles.

*Both aspects come together in the 2019 tile collection: The new designs, décors, finishes and formats represent the great diversity that characterises modern life and interpret the themes of concrete, natural stone, wood and colour in ceramics. The result: sophisticated tile ranges which capture the imagination and inspire the creation of rooms in which people like to live - completely individual and full of emotion.*

*Because Villeroy & Boch tiles are more than just beautiful wall and floor coverings. At every single stage, from the design to production and right through to the marketing, you will find a passion and love for what we do. You can sense it, and that's exactly why our philosophy is: Loving & Living Tiles.*

Leben am Puls der Zeit

*Living with the latest trends*



Ein Refugium für Körper, Geist und Seele – im pulsierenden Stadtleben ist das für viele ein Sehnsuchtsort. Warum sich nicht inmitten des Großstadtdschungels eine grüne Oase der Ruhe schaffen? In der eigenen Lebens- oder Arbeitswelt.

Das faszinierende Wand- und Bodenkonzept URBAN JUNGLE ist dafür wie gemacht: Ein starker Beton-Look in sanften Naturtönen, belebt mit Einschlüssen, die an handwerklichen Terrazzo erinnern. Und dazu eine raffinierte Dekoration mit üppigen, exotischen Pflanzen und schimmernder Glanz in ruhigem Grün – so geht Wellness.

# URBAN JUNGLE

Willkommen in der grünen Oase

*Welcome to an oasis of green*

*A refuge for body, mind and soul – this is what many are looking for to escape from throbbing city life. Why not create a green oasis of peace in the middle of the urban jungle? In your own living or working environment.*

*The fascinating URBAN JUNGLE wall and floor concept has the answer: A bold concrete look in soft natural tones, animated with inclusions reminiscent of handcrafted terrazzo. Plus a sophisticated décor featuring lush, exotic plants and a shimmering shine in calm green – that's how wellness works.*





Entspannung pur in den eigenen vier Wänden. Das dezente Dekor mit feinen Matt-Glanz-Effekten erzeugt eine herrlich entspannende Atmosphäre in jedem Raum.

*Pure relaxation within your own four walls. The discreet décor with its fine matt-gloss effects creates a wonderfully relaxing atmosphere in any room.*







Bodenfliesen · Floor tiles: URBAN JUNGLE dark grey | Dekor · Décor: URBAN JUNGLE green mix



Einfach, klar und faszinierend: Beton – eine Optik, die aus modernen Einrichtungen nicht mehr wegzudenken ist. Keramikfliesen, die typische Betonstrukturen adaptieren, sind daher perfekt für urban-puristische Interior Designs. So wie das Wand- und Bodenkonzept ATLANTA in einem reduzierten Betonlook mit Abnutzungsspuren.

Vom kleinen Mosaik bis zum aktuellen Großformat, in starken Farben für kühle oder warme Farbwelten, die man auch individuell mixen und kombinieren kann – das eröffnet jede Menge Gestaltungsfreiräume.

# ATLANTA

**Puristische Betonoptik in angesagtem Used-Look**

*Purist concrete effect in the popular used-look*

*Plain and simple, yet fascinating: Concrete – a look that has become an integral feature of modern furnishings. Ceramic tiles that adapt a structure typical of concrete are therefore perfect for urban-purist interior design. Such as the new ATLANTA wall and floor concept in a minimalist look of concrete with authentic traces of wear.*

*From small mosaics to the current large format tiles, in bold colours for both cool and warm colour schemes, and which can also be individually mixed and combined – there is plenty of scope for creative design.*

Was passiert, wenn Arbeiter in schweren Schuhen tagein tagaus Baumaterial über rustikale Baustellenbohlen tragen und Maschinen darüber schieben? Sie hinterlassen deutlich sichtbare Spuren. Diesen authentischen Look greift die Serie WORKSHOP auf und interpretiert Beton einmal ganz anders – extravagant und zeitgemäß im Sinne des angesagten Industrial Style.

Die Bodenfliesen reizen das Spiel mit Kontrasten in einer einzigartigen Farbe effektiv aus. Das Spektrum reicht von warmer Rostoptik über stahlgraue und anthrazitfarbene Betontöne bis hin zu cremigen und braunen Elementen. Wunderschön sanft dazu: Helle Wandfliesen und eine klassisch anmutende Reliefdekoration.

# WORKSHOP

Extravaganz im Industrial Style

*Extravagance in industrial style*

*What happens when workers in heavy shoes carry building materials over rustic construction site planks and push machines over them day in, day out? They leave clearly visible traces of wear. The WORKSHOP range takes up this authentic look and interprets the concrete in a completely different way - extravagant and contemporary - to reflect the popular industrial style.*

*The floor tiles emphasise the play of contrasts in a single colour to great effect. The spectrum ranges from a warm rust look to steely-grey and anthracite-coloured concrete shades to creamy and brown elements. And to complete the picture: Light wall tiles and a classic-looking relief décor.*

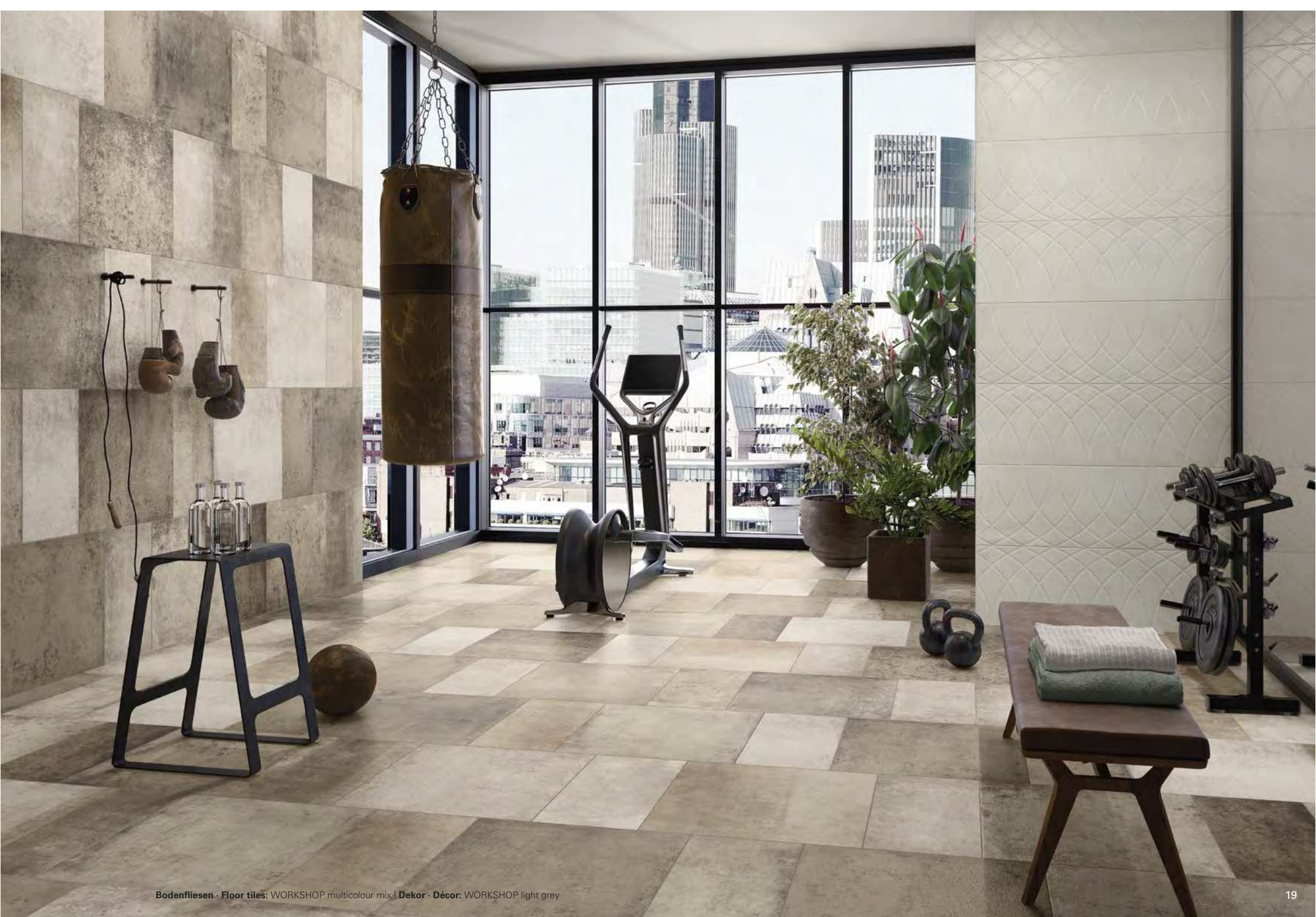

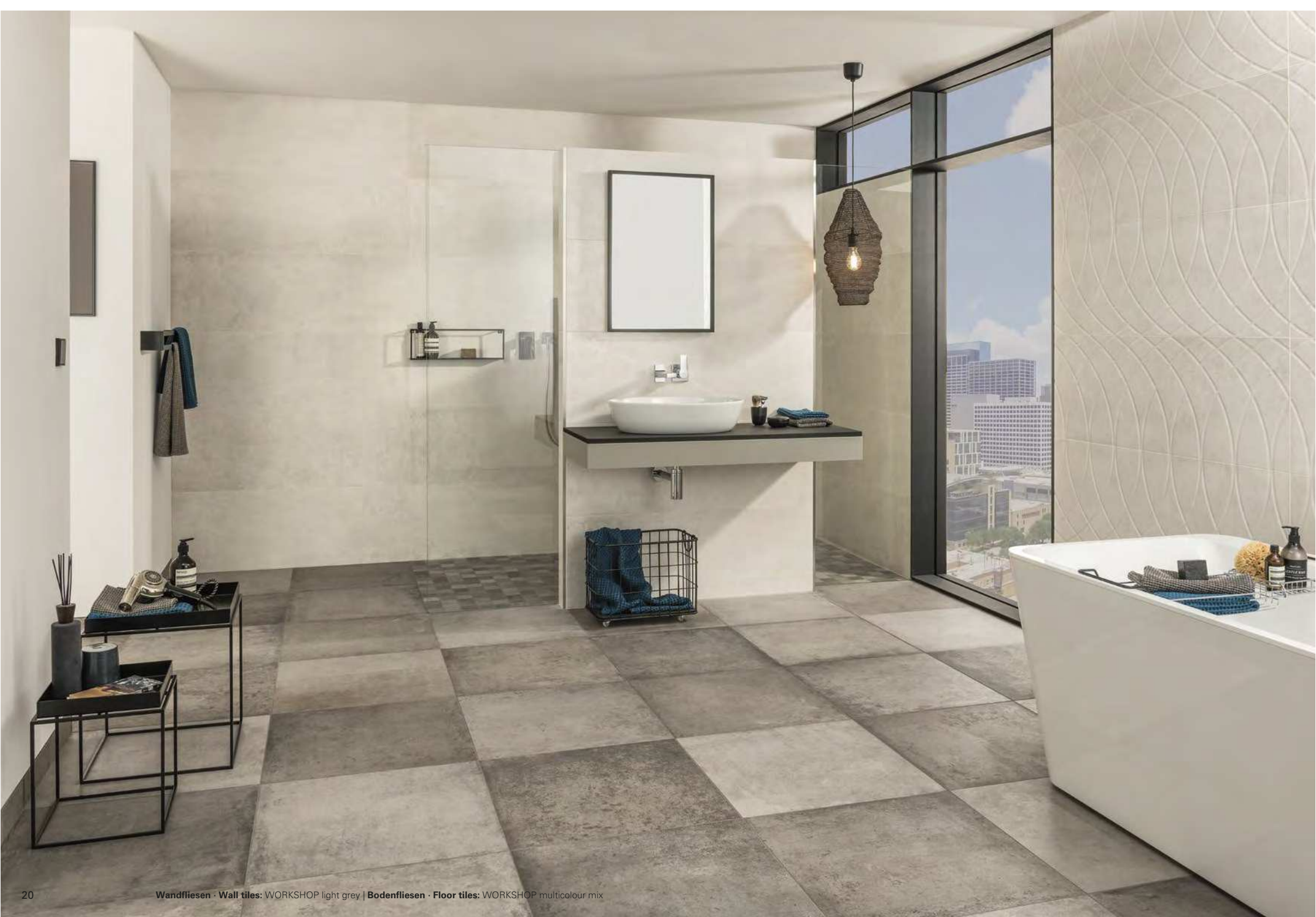

Die Faszination von Farbe

*The fascination of colour*



Die Farbe ist zurück! Neben Weiß, Grau und Creme halten wieder ausdrucksvolle Töne Einzug in die Inneneinrichtung. Besonders angesagt: unifarbene Wände, glatt oder fein strukturiert in trendstarker Farbigkeit.

Da kommt das Farbkonzept LIGHTPLAY mit seinen ausgesuchten Farbnuancen genau richtig. Besonderes Highlight: die neue, steinmatte Oberfläche PowderTouch. Sie betont die edle Anmutung der sieben pudrig-sanften Töne, die harmonisch aufeinander abgestimmt sind. Und für zusätzliche Wow-Effekte an der Wand sorgen eine Dekoration mit Textilstruktur und extra-schmale Metallleisten.

# LIGHTPLAY

Sanfte Farbtöne treffen samtige Oberflächen  
*Soft colours and velvety surfaces*

*Colour is back! In addition to white, grey and creme, expressive shades are once again finding their way into interior design. One-colour walls are currently particularly „en vogue“, smooth or finely structured in trendy colours.*

*And this is where the LIGHTPLAY colour concept with its subtle colour nuances really comes into its own. The new, stone matt surface PowderTouch is a special highlight. It emphasises the elegant appearance of the seven powdery, soft tones, which coordinate harmoniously. Additional stunning effects are provided on the walls by a décor with textile structure and extra-narrow metal strips.*



Wer schon einmal mit der Pariser U-Bahn gefahren ist, kennt die weißen Kacheln, die seit dem Bau der berühmten Metro zu Beginn des 20. Jahrhunderts in den Gängen und Bahnhöfen verlegt sind. Längst haben die berühmten Metro-Fliesen mit der typischen Facette den Untergrund verlassen und sind zu regelrechten Stil-Ikonen im Interior Design aufgestiegen.

Das Wandkonzept METRO FLAIR aus Facettenfliesen in drei Formaten und acht modernen Farben bringt urbanes Flair in die eigenen vier Wände und sorgt mit zahlreichen Kombinationsmöglichkeiten für ein neues, frisches Wohnerlebnis.

# METRO FLAIR

**Stil-Ikonen mit urbanem Retro-Charme**

*Icons of style with an urban retro charm*

*Anyone who has ever travelled on the Paris underground is familiar with the white tiles that were laid in the passageways and stations when the famous Métro was built at the beginning of the 20th century. The renowned Métro tiles with their characteristic facets have long since left the underground and become icons of style in interior design.*

*The METRO FLAIR wall concept with faceted tiles in three formats and eight modern colours brings urban flair to your own four walls and provides a new, fresh living experience with numerous combination options.*





Bodenfliesen · Floor tiles: LODGE greige | Wandfliesen · Wall tiles: METRO FLAIR alabaster

A serene sunset over a body of water with mountains in the background and reeds in the foreground. The sun is low on the horizon, casting a bright glow and a reflection on the water. The sky is filled with soft, golden light, and the mountains are silhouetted against the bright sky. In the foreground, several thin, dark reeds with feathery seed heads are visible, some in focus and some blurred.

Die Schönheit der Natur

*The true beauty of nature*

Vom besonderen Charme der norditalienischen Landschaft rund um den Comer See erzählt die Fliesenserie BELLAGIO. Das Design ist eine neuartige Steininterpretation, die natürliche Ursprünglichkeit mit trendstarken Aspekten belebt: Marmor trifft Terrazzo - eine einzigartige Kombination, die es so in der Natur nicht gibt. Und die deshalb so fasziniert.

Die feine Marmoroptik erhält durch die dezenten Einschlüsse, die wie Terrazzo aussehen, einen überraschenden und zugleich ausgesprochen modernen Look. Damit ist das Wand- und Bodenkonzept wie gemacht für puristische Interieurs und auch im klassischen Ambiente wunderschön.

# BELLAGIO

**Marmor trifft Terrazzo**

*Marble meets terrazzo*

*The BELLAGIO tile range tells of the special charm of the northern Italian landscape around Lake Como. The design is a fresh interpretation of natural stone, which enlivens natural originality with trend-setting aspects: Marmor meets terrazzo - a unique combination that cannot be found in nature. And which is therefore so fascinating.*

*Discreet inclusions reminiscent of terrazzo give the fine marble touch a decidedly modern appeal. This wall and floor concept is therefore ideal for purist interiors and also a wonderful choice for a classic setting.*







**Bodenfliesen** · Floor tiles: BELLAGIO shadow | **Wandfliesen** · Wall tiles: BELLAGIO light shadow



Natursteinoptiken sind zeitlos-modern – ideal für Gestaltungen, die lange schön bleiben und ihren besonderen Reiz behalten sollen. Immer aktuell ist Schiefer, der in seinen vielen Gesteinslagen immer wieder neue Muster, Strukturen und Farben zeigt – entstanden vor Millionen Jahren durch die Oxidation verschiedener Metalle zwischen den Schichten.

Das Feinsteinzeugkonzept GATEWAY überträgt die raue Struktur von Schiefer in ein dezentes Relief, das die typischen Schichtungen sanft abbildet. So entsteht ein sehr feines Oberflächenbild, das in der Fläche besonders schön wirkt. Überraschender Aspekt: Neben drei naturnahen Farben gibt es einen hellen Ton, den man bei Schiefer so nicht erwartet.

# GATEWAY

Dezente Schieferoptik in ausdrucksvollen Farben  
*Subtle slate look in expressive colours*

*The natural stone look is timelessly modern – ideal for designs that are to remain beautiful for a long time and retain a special charm. Slate is always up-to-date, displaying continuously changing patterns, structures and colours in the many layers of rock – formed millions of years ago by the oxidation of various metals between the different layers.*

*The GATEWAY porcelain stoneware concept interprets the rough texture of slate and transposes it to a subtle relief which softly represents the strata typical of slate. This creates a very fine finish and a particularly beautiful effect over a large surface. Surprising feature: In addition to the three natural colours there is also a light shade one would not expect to find in slate.*







Bodenfliesen · Floor tiles: GATEWAY OUTDOOR manhattan grey



Holz bringt natürliches Flair in jeden Raum. Darum sind auch Fliesen mit hochwertiger Holzoptik so beliebt: Sie sehen nicht nur wunderbar authentisch aus, sondern fühlen sich sogar an wie echtes Holz.

Das Feinsteinzeugkonzept OAK PARK besitzt die ruhige Anmutung von Eichenholz, fein gemasert mit sanften Verläufen und einem leichten Relief. Farben und Formate betonen den natürlichen Charme: Sechs Holzfarben mit authentischen Schattierungen in drei typischen Dielenformaten sind perfekt für harmonische oder lebendige Beläge drinnen und draußen.

# OAK PARK

Die ruhige **Anmutung** von **Eiche**

*The calming charm of oak*

*Wood brings natural flair to any room. That's why tiles with a high-quality wood look are so popular: Not only do they look beautifully authentic they even feel like real wood.*

*The OAK PARK porcelain stoneware concept introduces the calming charm of oak wood, fine-grained with gentle gradients and a slight relief. The colours and formats emphasise the natural charm: Six wood tones that feature authentic shading in three typical plank formats are perfect for harmonious or lively coverings indoors and out.*









Eine Stadt wie eine Landschaft aus Granit: Aberdeen, die abgelegene Hafenstadt hoch oben im Nordosten Schottlands. Historische Gebäude aus silbergrauen Steinen prägen das Stadtbild und sind Inspiration für das Design der Wand- und Bodenserie ABERDEEN.

Naturstein zeitgemäß interpretiert: Eine matte Granitoptik am Boden wird mit einer dezenten Steinanmutung mit feinen Glanz-Effekten an der Wand kombiniert. Ausdrucksvolle Farben und sanfte Reliefs machen das detailreiche Design authentisch und neu zugleich. Perfekt für Wände und Böden in puristischen oder rustikalen Einrichtungen.

# ABERDEEN

Inspiriert vom silbergrauen Granit Schottlands

*Inspired by the silver-grey granite of Scotland*

*A city with the air of a landscape made of granite: Aberdeen, the remote port city in the far north-east of Scotland. Historical buildings made of silver-grey stones characterise the cityscape and are the inspiration for the design of the ABERDEEN tile range for walls and floors.*

*A contemporary interpretation of natural stone: A matt granite look for the floor is combined with a discreet stone look with fine gloss effects for walls. Expressive colours and a delicate relief effect ensure that the detailed design is both new and authentic at the same time. Simply perfect for walls and floors in purist or rustic interiors.*





Bodenfliesen · Floor tiles: ABERDEEN slate grey

*Loving &  
Living Tiles*

# Produktübersichten

## *Overview of Products*

ABERDEEN	52
ATLANTA	55
BELLAGIO	58
GATEWAY	60
LIGHTPLAY	62
METRO FLAIR	63
OAK PARK	64
URBAN JUNGLE	66
WORKSHOP	69

# ABERDEEN

Grundfliesen aus Steingut (nur für die Wand geeignet)  
*Nonvitreous basic tiles (suitable for walls only)*

Art. 1733 · 33 x 100 cm  
 white pearl



SB00   
 

Art. 1581 · 30 x 60 cm  
 white pearl



SB00   
 

Grundfliesen aus Feinsteinzeug (für Wand und Boden geeignet)  
*Porcelain stoneware basic tiles (suitable for walls and floors)*

Art. 2577 · 60 x 60 cm  
 pearl



SB10   
   

opal grey



SB60   
   

tobacco



SB70   
   

























slate grey



SB90   
   





30 x 60 cm

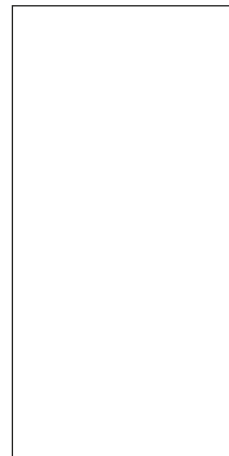

Art. 2576     Art. 2526 <sup>1)</sup>      
 SB10 · SB60 SB1R · SB6R  
 SB70 · SB90 SB7R · SB9R  
 Art. 2685 <sup>1)</sup>     Art. 2536 <sup>1)</sup>      
 SB1M · SB6M SB1V · SB6V  
 SB7M · SB9M SB7V · SB9V  
       





Art. 2987  
 60 x 120 cm

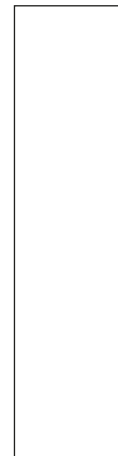

SB10 · SB60  
 SB70 · SB90  
   

Art. 2988  
 30 x 120 cm



SB10 · SB60  
 SB70 · SB90  
   



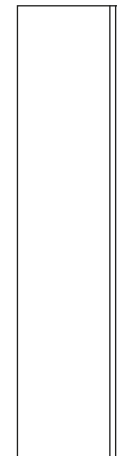

Art. 2732 <sup>1)</sup>  
 30 x 120 cm



SB10 · SB60  
 SB70 · SB90  
   





Art. 2620 <sup>1)</sup>  
 15 x 60 cm



SB10 · SB60 · SB70 · SB90  
   









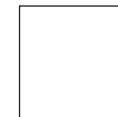























Art. 2617 <sup>1)</sup>  
 7,5 x 60 cm



SB10 · SB60 · SB70 · SB90  
   

































30 x 30 cm



Art. 2628 <sup>1)</sup>     Art. 2628 <sup>1)</sup>      
 SB10 · SB60 SB1R · SB6R  
 SB70 · SB90 SB7R · SB9R  
         
 Art. 2628 <sup>1)</sup>     Art. 2628 <sup>1)</sup>      
 SB1M · SB6M SB1V · SB6V  
 SB7M · SB9M SB7V · SB9V  
       

15 x 15 cm



Art. 2636 <sup>1)</sup>     Art. 2636 <sup>1)</sup>      
 SB10 · SB60 SB1R · SB6R  
 SB70 · SB90 SB7R · SB9R  
         
 Art. 2636 <sup>1)</sup>     Art. 2636 <sup>1)</sup>      
 SB1M · SB6M SB1V · SB6V  
 SB7M · SB9M SB7V · SB9V  
       

# ABERDEEN

Grundfliesen aus Feinsteinzeug (für Wand und Boden geeignet)  
 Porcelain stoneware basic tiles (suitable for walls and floors)

Art. 2846 · 80 x 80 cm  
 pearl



SB10  
 \* R10 A

opal grey



SB60  
 \* R10 A

tobacco



SB70  
 \* R10 A

slate grey



SB90  
 \* R10 A

Art. 2845  
 40 x 80 cm



SB10 · SB60  
 SB70 · SB90  
 \* R10 A

Art. 2013  
 7,5 x 7,5 cm

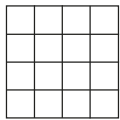

SB10 · SB60  
 SB70 · SB90  
 \* R10 B

Art. 2135  
 2,5 x 15 cm

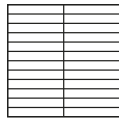

SB10 · SB60  
 SB70 · SB90  
 \* R10 A

Art. 2075  
 30 x 30 cm

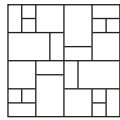

SB10 · SB60  
 SB70 · SB90  
 \* R10 A

## OUTDOOR TILES

Art. 2843  
 60 x 120 cm

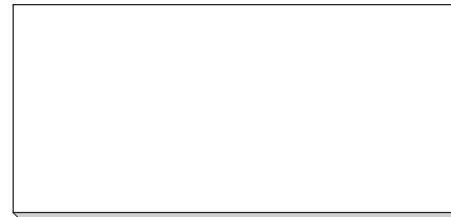

SB60 · SB70 · SB90  
 \* R10 A

## OUTDOOR TILES

Art. 2838  
 60 x 60 cm

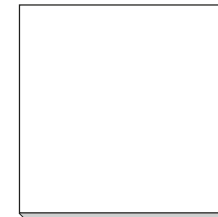

SB60 · SB70 · SB90  
 \* R10 A

Art. 2872 · 7,5 x 60 cm  
 Sockel  
 Skirting

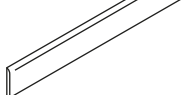

SB10 · SB60  
 SB70 · SB90  
 \*

Art. 2493 · 10 x 30 cm  
 Hohlkehlssockel  
 Cove base

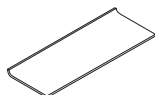

SB10 · SB60  
 SB70 · SB90  
 \*

## OUTDOOR TILES

Art. 2885 · 35 x 120 cm

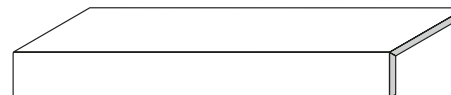

SB60 · SB70 · SB90  
 \* R10 A  
 Schenkelplatte  
 Nosing tile

## OUTDOOR TILES

Art. 2883 · 35 x 60 cm

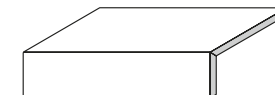

SB60 · SB70 · SB90  
 \* R10 A  
 Schenkelplatte  
 Nosing tile



# ABERDEEN

Variationsvielfalt | *Shade variation*



60 x 60 cm | pearl



60 x 60 cm | opal grey



60 x 60 cm | tobacco



60 x 60 cm | slate grey



# ATLANTA

Grundfliesen aus Steingut (nur für die Wand geeignet)  
*Nonvitreous basic tiles (suitable for walls only)*

Art. 1733 · 33 x 100 cm  
 light alabaster



AL10   
 

light fog



AL00   
 

Art. 1581  
 30 x 60 cm



AL10 · AL00  
 

Grundfliesen aus Feinsteinzeug (für Wand und Boden geeignet)  
*Porcelain stoneware basic tiles (suitable for walls and floors)*

Art. 2660 · 60 x 60 cm  
 alabaster white



AL10   
  R10



sandy grey



AL70   
  R10

dark coffee



AL80   
  R10



foggy grey



AL40   
  R10



concrete grey



AL60   
  R10



night grey



AL90   
  R10

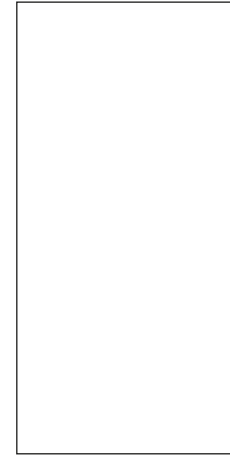

Art. 2730  
 60 x 120 cm



AL10 · AL70 · AL80  
 AL40 · AL60 · AL90  
  R10

Art. 2394  
 30 x 60 cm



AL10 · AL70 · AL80  
 AL40 · AL60 · AL90  
  R10

Dekorfliese aus glasiertem Feinsteinzeug (für Wand und Boden geeignet)  
*Porcelain glazed stoneware basic tiles (suitable for walls and floors)*

Art. 2660 · 60 x 60 cm  
 sand multicolor



AL75   
  R10

grey multicolor



AL65   
  R10

# ATLANTA

Grundfliesen aus Feinsteinzeug (für Wand und Boden geeignet)  
*Porcelain stoneware basic tiles (suitable for walls and floors)*

Art. 2810 · 80 x 80 cm  
 alabaster white



AL10  
 ✱ R10

sandy grey



AL70  
 ✱ R10

dark coffee



AL80  
 ✱ R10

Art. 2840  
 40 x 80 cm



AL10 · AL70 · AL80  
 AL40 · AL60 · AL90  
 ✱ R10

foggy grey



AL40  
 ✱ R10

concrete grey



AL60  
 ✱ R10

night grey



AL90  
 ✱ R10

Art. 2656  
 30 x 60 cm



AL69  
 ✱ R10



AL79  
 ✱ R10

Art. 2013  
 7,5 x 7,5 cm

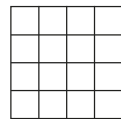

AL10 · AL70 · AL80  
 AL40 · AL60 · AL90  
 ✱ R10 B

Art. 2872  
 7,5 x 60 cm

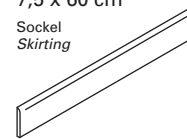

Socket  
 Skirting  
 AL10 · AL70 · AL80  
 AL40 · AL60 · AL90  
 ✱

# ATLANTA

Variationsvielfalt | *Shade variation*

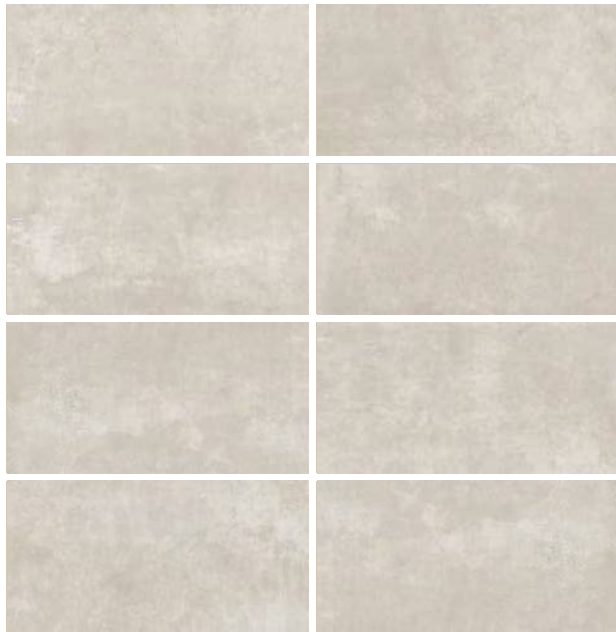

60 x 120 cm | alabaster white

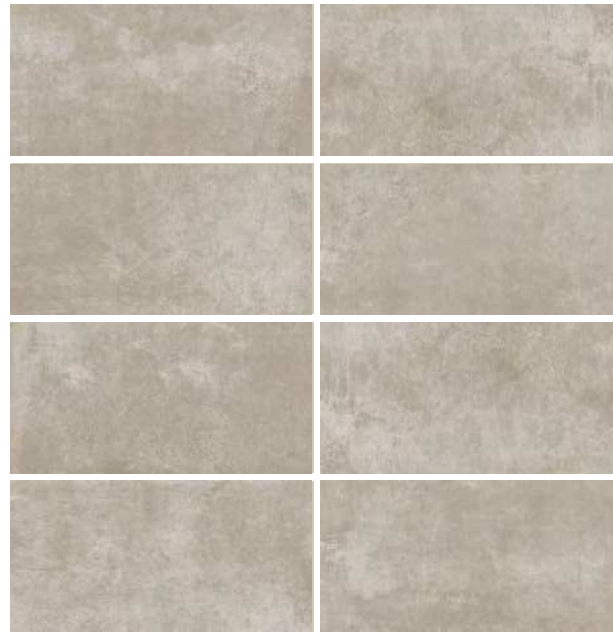

60 x 120 cm | sandy grey

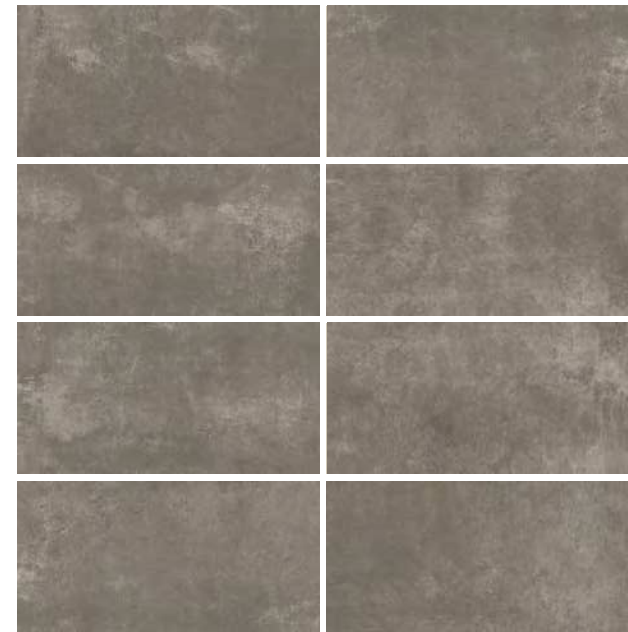

60 x 120 cm | dark coffee

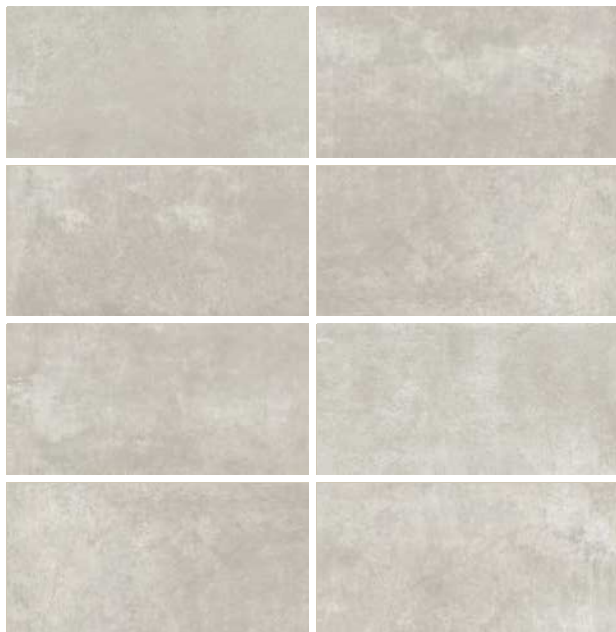

60 x 120 cm | foggy grey

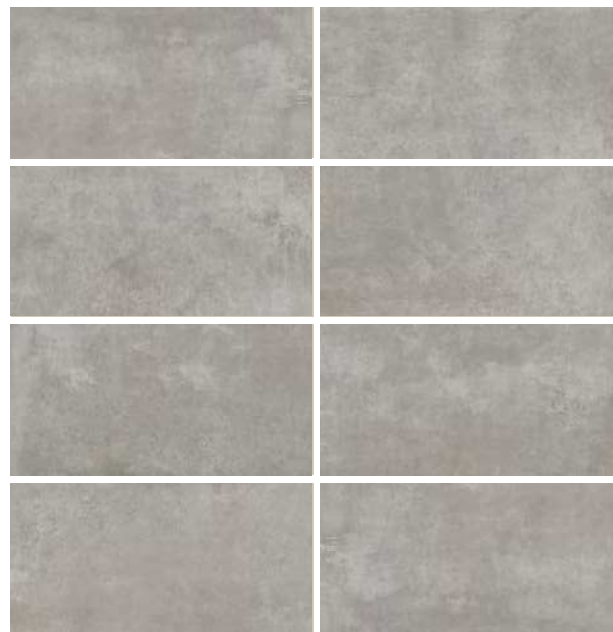

60 x 120 cm | concrete grey

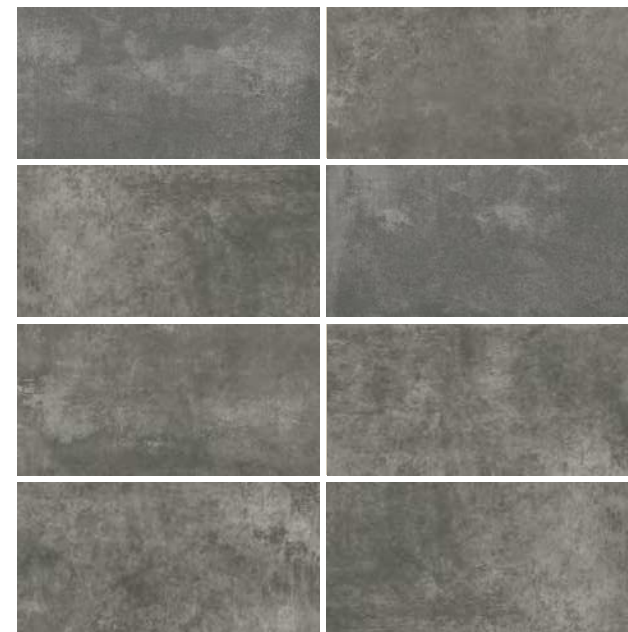

60 x 120 cm | night grey



# BELLAGIO

Grundfliesen aus Steingut (nur für die Wand geeignet)  
*Nonvitreous basic tiles (suitable for walls only)*

Art. 1440 · 40 x 120 cm  
 light shadow



TM01  2  
 

Art. 1581  
 30 x 60 cm





TM01  2  
 

Grundfliesen und Dekorfliesen aus Feinsteinzeug (für Wand und Boden geeignet)  
*Porcelain stoneware basic tiles and décor tiles (suitable for walls and floors)*

Art. 2730 · 60 x 120 cm  
 shadow



TM6M  2  
   R9  
 TM6L  
 

Art. 2660  
 60 x 60 cm

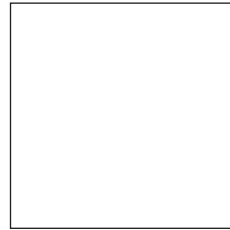

TM6M  
   R9  
 TM6L  
 

Art. 2394  
 30 x 60 cm



TM6M  
   R9  
 TM6L  
 

Art. 2078  
 30 x 30 cm



TM60  
   R9

Art. 2079  
 30 x 30 cm



TM60  
   R9  
 2 Stück im Set  
 2 piece set

Art. 2030  
 5 x 5 cm

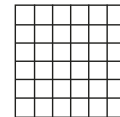

TM6M  
   R9  A

Art. 2872  
 7,5 x 60 cm

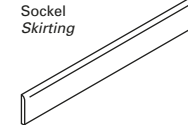

Socket  
 Skirting  
 TM6M  
   
 TM6L  
 

# BELLAGIO

Variationsvielfalt | *Shade variation*



60 x 120 cm | shadow



40 x 120 cm | light shadow



# GATEWAY

Grundfliesen aus Feinsteinzeug (für Wand und Boden geeignet)  
 Porcelain stoneware basic tiles (suitable for walls and floors)

vilbostoneplus

**vilbostone**  
 Feinsteinzeug · Porcelain stoneware

Art. 2542 · 60 x 60 cm  
 foggy white



SR10 2  
 \* R10

manhattan grey



SR60 3  
 \* R10

dark olive



SR50 4  
 \* R10

midnight black

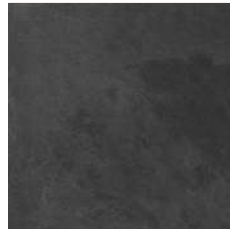

SR90 3  
 \* R10

Art. 2546 <sup>1)</sup>  
 60 x 60 cm

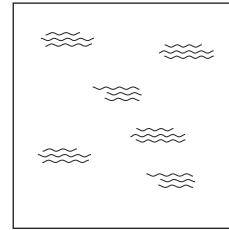

SR10 · SR60  
 SR50 · SR90  
 \* R11

OUTDOOR TILES  
 Art. 2834 · 60 x 60 cm

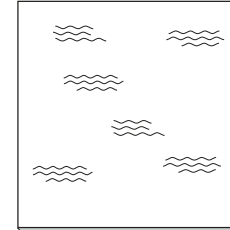

SR60 · SR90  
 \* R11

OUTDOOR TILES  
 Art. 2883 · 35 x 60 cm

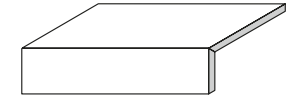

SR60 · SR90  
 \* R11   
 Schenkelplatte  
 Nosing tile

Art. 2556  
 60 x 120 cm

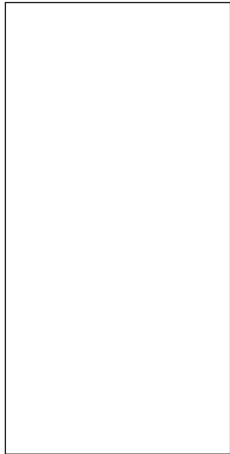

SR10 · SR60  
 SR50 · SR90  
 \* R10

Art. 2457  
 30 x 120 cm



SR10 · SR60  
 SR50 · SR90  
 \* R10

Art. 2732  
 30 x 120 cm

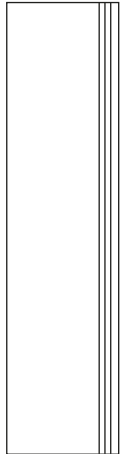

SR10 · SR60  
 SR50 · SR90  
 \* R10

Treppenauftritt  
 Stair tread

Art. 2539  
 30 x 60 cm



SR10 · SR60  
 SR50 · SR90  
 \* R10

Art. 2620 <sup>1)</sup>  
 15 x 60 cm



SR10 · SR60  
 SR50 · SR90  
 \* R10

Art. 2617 <sup>1)</sup>  
 7,5 x 60 cm



SR10 · SR60  
 SR50 · SR90  
 \* R10

Art. 2685 <sup>1)</sup>  
 30 x 60 cm

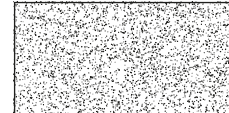

SR10 · SR60  
 SR50 · SR90  
 \* R10

Art. 2013  
 7,5 x 7,5 cm

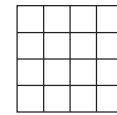

SR10 · SR60  
 SR50 · SR90  
 \* R10

Art. 2531 <sup>1)</sup>  
 30 x 60 cm

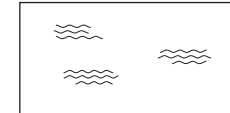

SR10 · SR60  
 SR50 · SR90  
 \* R11

Art. 2872  
 7,5 x 60 cm

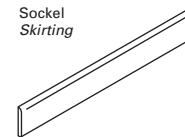

SR10 · SR60  
 SR50 · SR90  
 \*

# GATEWAY

Variationsvielfalt | *Shade variation*



60 x 60 cm | foggy white



60 x 60 cm | dark olive



60 x 60 cm | manhattan grey



60 x 60 cm | midnight black





# LIGHTPLAY

Grundfliesen und Dekorfliesen aus Steingut (nur für die Wand geeignet)  
*Nonvitreous basic tiles and décor tiles (suitable for walls only)*

Art. 1733 · 33 x 100 cm

marsala



PW35



nude

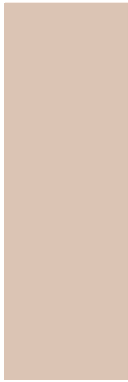

PW30



canvas

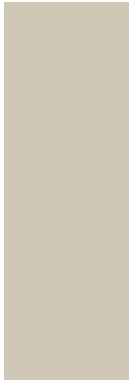

PW70



cotton

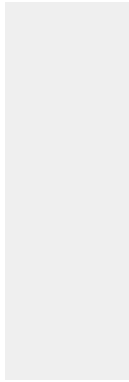

PW10



ash grey

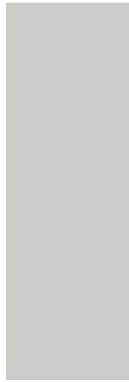

PW60



velvet leaf



PW50



pastel blue



PW40



Art. 1734 · 33 x 100 cm

marsala



PW35



nude



PW30



canvas



PW70



cotton

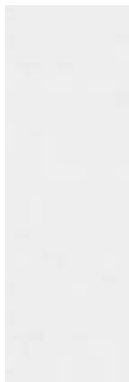

PW10



ash grey



PW60



velvet leaf



PW50



pastel blue



PW40



Metallleiste · *Metal strip*

Art. 1045 · 0,5 x 100 cm

brass



PW22



copper



PW33



silver



PW66



Art. 1233

33 x 50 cm

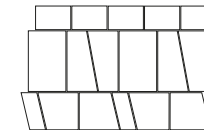

PW35 · PW60

PW30 · PW50

PW70 · PW40

PW10



Passende Bodenfliesen · *Recommended floor tiles:*  
 ABERDEEN, OAK PARK

# METRO FLAIR

Grundfliesen aus Steingut (nur für die Wand geeignet)  
Nonvitreous basic tiles (suitable for walls only)

Art. 1210 · 10 x 10 cm

snow



MW00



alabaster



MW10



clay



MW70



light dove



MW60



midnight



MW90



sage



MW50



mystic navy



MW40



berry



MW30



Art. 1212 · 10 x 20 cm

snow

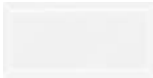

MW00



alabaster



MW10



clay



MW70



light dove



MW60



midnight



MW90



sage



MW50



mystic navy

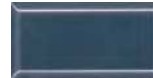

MW40



berry



MW30



Art. 1220 · 20 x 20 cm

snow



MW00



alabaster



MW10



clay



MW70



light dove



MW60



midnight



MW90



sage



MW50



mystic navy



MW40



berry



MW30



# OAK PARK

Grundfliesen aus Feinsteinzeug (für Wand und Boden geeignet)  
 Porcelain stoneware basic tiles (suitable for walls and floors)

vilbostoneplus

**vilbostone**  
 Feinsteinzeug · Porcelain stoneware

Art. 2793 · 30 x 120 cm

farina



HR00 2  
 R9

crema



HR10 2  
 R9

chalet



HR20 2  
 R9

brandy



HR30 2  
 R9

cacao



HR80 2  
 R9

caviar



HR90 2  
 R9

Art. 2792  
 20 x 120 cm

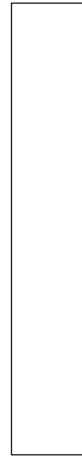

HR00 · HR10 · HR20  
 HR30 · HR80 · HR90  
 R9

OUTDOOR TILES  
 Art. 2821 · 40 x 120 cm

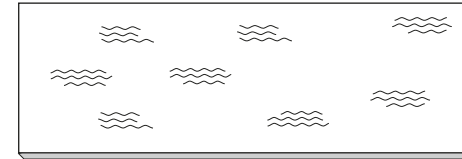

HR10 · HR20 · HR30 · HR80  
 R11 B

OUTDOOR TILES  
 Art. 2885 · 35 x 120 cm



HR10 · HR20 · HR30 · HR80  
 R11 B  
 Schenkelplatte  
 Nosing tile

Art. 2135  
 2,5 x 15 cm

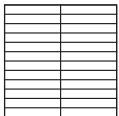

HR00 · HR10 · HR20  
 HR30 · HR80 · HR90  
 R9 A

Art. 2013  
 7,5 x 7,5 cm

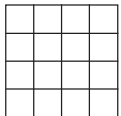

HR00 · HR10 · HR20  
 HR30 · HR80 · HR90  
 R9 A

Art. 2139  
 7,5 x 120 cm

Sockel  
 Skirting

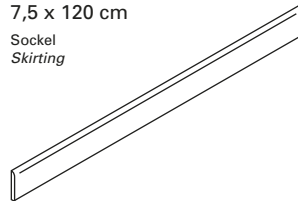

HR00 · HR10 · HR20  
 HR30 · HR80 · HR90  
 R9

# OAK PARK

Variationsvielfalt | *Shade variation*



20 x 120 cm | farina



20 x 120 cm, 30 x 120 cm | crema



30 x 120 cm | chalet



20 x 120 cm | brandy



20 x 120 cm, 30 x 120 cm | cacao



30 x 120 cm | caviar



# URBAN JUNGLE

Grundfliesen und Dekorfliesen aus Steingut (nur für die Wand geeignet)  
*Nonvitreous basic tiles and décor tiles (suitable for walls only)*

Art. 1440 · 40 x 120 cm  
white grey



TC00



soft greige

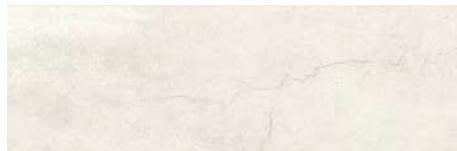

TC20



Art. 1440 · 40 x 120 cm  
green mix



TC50



Art. 1581 · 30 x 60 cm  
green mix



TC50



Art. 1581 · 30 x 60 cm  
white grey



TC00



soft greige



TC20



Art. 1440 · 40 x 120 cm  
white grey jungle

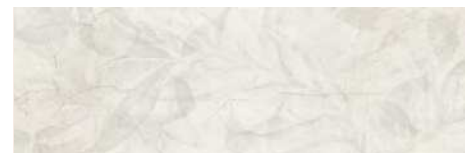
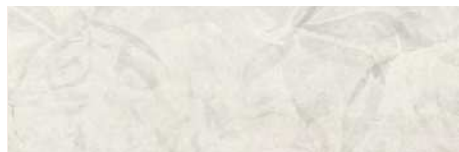

TC01



3 Stück im Set  
3 piece set

soft greige jungle

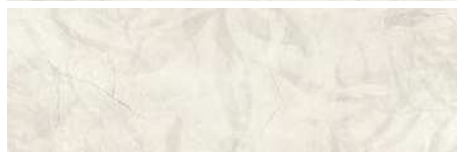
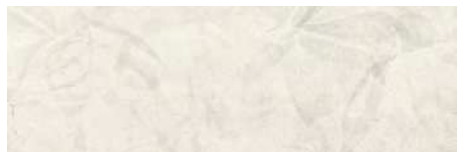

TC21



3 Stück im Set  
3 piece set

Art. 1440 · 40 x 120 cm  
wild jungle grey



TC05



3 Stück im Set  
3 piece set

wild jungle greige



TC25



3 Stück im Set  
3 piece set

# URBAN JUNGLE

Grundfliesen aus Feinsteinzeug (für Wand und Boden geeignet)  
 Porcelain stoneware basic tiles (suitable for walls and floors)

Art. 2660 · 60 x 60 cm  
 light grey



TC10 TC60  
 ✱ ✱ R9

greige



TC70 TC60  
 ✱ ✱ R9

grey



TC60 TC90  
 ✱ ✱ R9

dark grey



TC90 TC60  
 ✱ ✱ R9

Art. 2394  
 30 x 60 cm



TC10 · TC70  
 TC60 · TC90  
 ✱ ✱ R9

Art. 2733  
 45 x 45 cm



TC10 · TC70  
 TC60 · TC90  
 ✱ R9

Art. 2013  
 7,5 x 7,5 cm

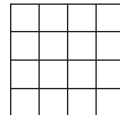

TC10 · TC70  
 TC60 · TC90  
 ✱ ✱ R9 A

Art. 2052 · 30 x 60 cm  
 multicolour



TC99  
 ✱ ✱ R9 A

Art. 2872  
 7,5 x 60 cm  
 Sockel  
 Skirting

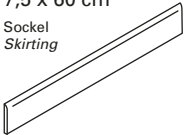

TC10 · TC70  
 TC60 · TC90  
 ✱ ✱

Art. 2717  
 8 x 45 cm  
 Sockel  
 Skirting

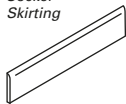

TC10 · TC70  
 TC60 · TC90  
 ✱

Art. 2810  
 80 x 80 cm

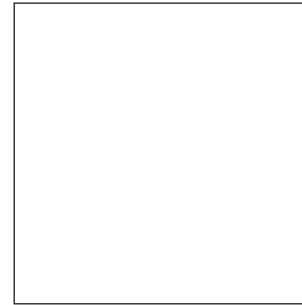

TC10 · TC70 · TC60 · TC90  
 ✱ ✱ R9

OUTDOOR TILES  
 Art. 2888 · 80 x 80 cm

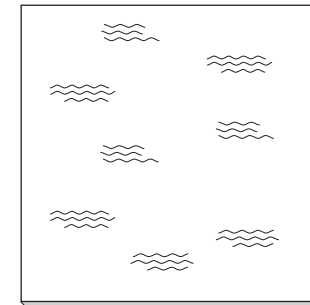

TC10 · TC70 · TC60 · TC90  
 ✱ ✱ R11 B

OUTDOOR TILES  
 Art. 2884 · 35 x 60 cm



SR60 · SR90  
 ✱ ✱ R11 B  
 Schenkelplatte  
 Nosing tile

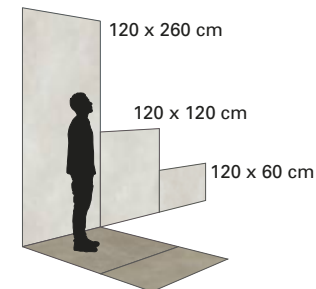

OPTIMA: auch in den Formaten 60 x 120, 120 x 120 und 120 x 260 cm in 6 mm erhältlich.  
 OPTIMA: also available in the formats 60 x 120, 120 x 120 and 120 x 260 cm in 6 mm thickness.

# URBAN JUNGLE

Variationsvielfalt | *Shade variation*

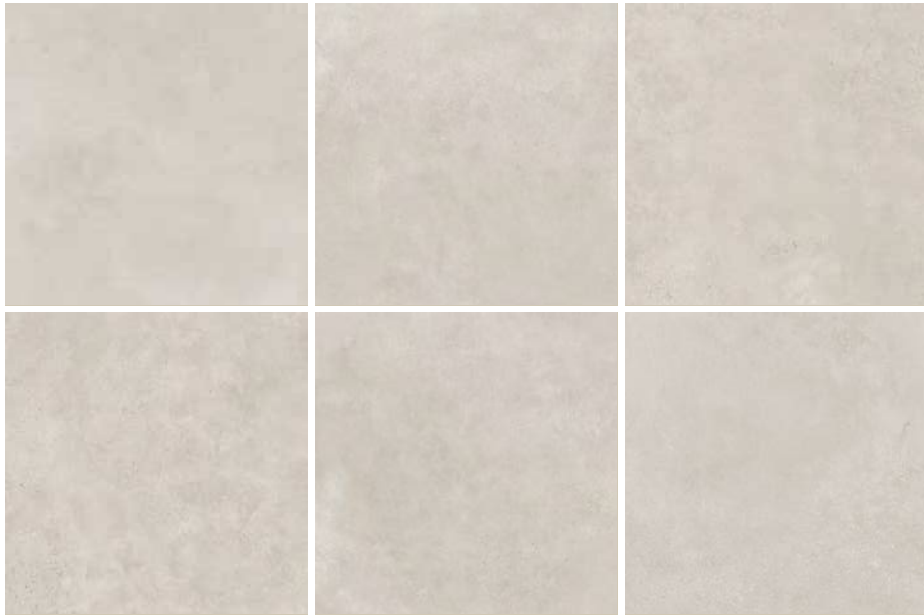

60 x 60 cm | light grey



60 x 60 cm | greige



60 x 60 cm | grey



60 x 60 cm | dark grey



# WORKSHOP

**Grundfliesen und Dekorfliesen aus Steingut (nur für die Wand geeignet)**  
*Nonvitreous basic tiles and décor tiles (suitable for walls only)*

Art. 1440 · 40 x 120 cm  
light grey



BC00   



Art. 1486 · 40 x 120 cm  
light grey



BC00   

Art. 1581 · 30 x 60 cm  
light grey



BC00   

Art. 1597 · 30 x 60 cm  
light grey



BC00   



# WORKSHOP

Grundfliesen aus Feinsteinzeug (für Wand und Boden geeignet)  
*Porcelain stoneware basic tiles (suitable for walls and floors)*

Art. 2871 - 60 x 60 cm  
 multicolour mix



BC30



Art. 2870  
 30 x 60 cm



BC30

Art. 2071  
 30 x 50 cm



BC30

Art. 2013  
 7,5 x 7,5 cm

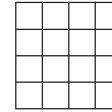

BC30

Art. 2872  
 7,5 x 60 cm

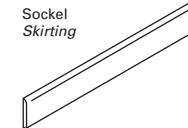

BC30



## ceramicplus

Villeroy & Boch

Unsere Wandfliesen aus Steingut sind werkseitig mit **ceramicplus** ausgestattet. Mit dieser pflegeleichten Oberfläche brauchen unsere Fliesen wesentlich weniger Pflege. Zur Reinigung genügen oft nur Wasser und ein Tuch, aggressive Reiniger werden überflüssig.

*The **ceramicplus** finish is applied to our nonvitreous wall tiles at the factory. Our tiles thus require much less care. Often, the only cleaning materials that are required are water and a cloth; aggressive cleaning agents are redundant.*



## PowderTouch

Steingut · Nonvitreous

Innovative Matt-Finish-Glasur für Fliesen aus Steingut. Die Glasur verleiht den Wandfliesen eine ultramatte Oberflächenanmutung mit einer pudrig-sanften Haptik und lässt die Farben edel und modern wirken.

*Innovative matt-finish glaze for nonvitreous tiles. This glaze gives wall tiles an ultra-matt surface finish with a powdery soft feel and makes colours look exquisite and modern.*



## concept<sup>3</sup>

Die concept<sup>3</sup>-Serien sind durchdachte Wand- und Bodenkonzepte, bei denen alles bis ins kleinste Detail zusammenpasst: Die Farben, Formate, Designs und Dekorationen der Wandfliesen aus Steingut und hochwertigen Bodenfliesen aus vilbostone Feinsteinzeug sind so perfekt aufeinander abgestimmt, dass sie ästhetische Raumgestaltungen wie aus einem Guss ermöglichen – ganz individuell und dabei immer stilsicher.

*The concept<sup>3</sup> ranges are sophisticated wall and floor concepts in which everything matches, down to the smallest detail: the colours, formats, designs and decorations of the nonvitreous wall tiles and of the high-quality floor tiles made of vilbostone porcelain stoneware match up so perfectly that they permit seamless aesthetic interior designs – very individual and always stylish.*

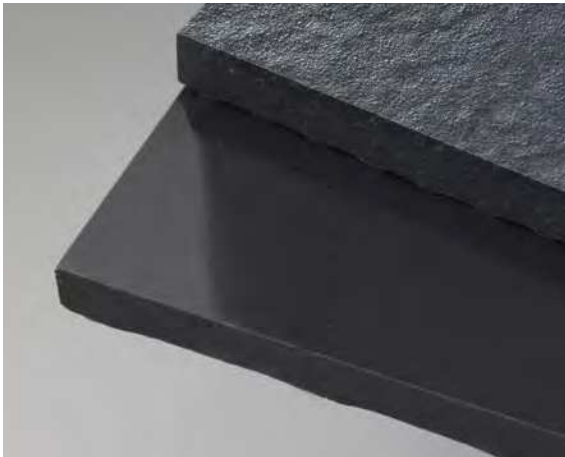

## vilbostone

Feinsteinzeug · Porcelain stoneware

vilbostone Feinsteinzeug ermöglicht eine Vielzahl unterschiedlicher Oberflächen-Designs mit außergewöhnlichen Farb- und Glanzeffekten. Erhältlich ist vilbostone Feinsteinzeug als unglasiertes und glasiertes Material mit matten, polierten, anpolierten sowie relieferten Oberflächen und mit unterschiedlichen Rutschhemmungen.

*vilbostone porcelain stoneware permits a wealth of different surface designs featuring unusual colour and sheen effects. vilbostone porcelain stoneware is available both glazed and unglazed, with a matt, polished, rough-polished or relief surface finish and in various classes of slip resistance.*



## vilbostoneplus













Das unglasierte vilbostone Feinsteinzeug ist in matter und anpolierter Ausführung mit der Oberflächenversiegelung vilbostoneplus ausgestattet, das die Fliesen unempfindlich gegen Schmutz und Flecken macht. Während des Herstellungsprozesses der Fliesen wird die Struktur ihrer Oberflächen so versiegelt, dass die Fleck- und Schmutzbeständigkeit weiter zunimmt und eine Nachbehandlung mit Imprägniermitteln nicht mehr erforderlich ist.

*Unglazed vilbostone porcelain stoneware with a matt or rough-polished surface finish have the vilbostoneplus seal, which renders the tiles particularly resistant to dirt and stains. During the manufacturing process, the structure of the tile surface is sealed in order to further increase the tiles' resistance to staining and dirt, as a result of which subsequent treatment with impregnating agents is no longer necessary.*

## Zeichenschlüssel

### **1 2 3 4 5** Abriebgruppe (DIN EN ISO 10545-7)













Die Abriebgruppe beschreibt die Verschleißeigenschaft von Fliesen aus glasiertem Steinzeug. Es werden 5 Abriebgruppen unterschieden: von 1 (sehr leichte Beanspruchung) bis 5 (starke Beanspruchung)

-  Rutschhemmung im gewerblichen Bereich
-  Rutschhemmung im Barfußbereich
-  Frostbeständig nach DIN EN ISO 10545-12
-  Rektifiziert
-  Edelmetallaufgabe. Kratzempfindliches Dekor. Reinigung nur mit Wasser und Geschirrspülmittel. Verfugung nur mit geeigneten, fein aufgemahlten, quarzarmen Fugenfüllern.
-  Fliesenstärke 20 mm
-  Fliesenstärke 6 mm
-  **ceramicplus**
-  **vilbostoneplus** Oberflächenversiegelung
-  **PowderTouch** Matte, pudrige Premiumglasur
-  **concept<sup>3</sup>** Komplettes Wand- und Bodenkonzept
-  **1 2 3 4** Variationsvielfalt

## Signs and symbols

### **1 2 3 4 5** Wear-resistance group (DIN EN ISO 10545-7)

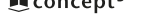
The wear-resistance group defines the wearing properties of tiles in glazed vitreous. A distinction is made between 5 wear-resistance groups, from 1 (suitable for minimal stress) to 5 (suitable for high levels)

-  *Anti-slip in workshop areas*
-  *Anti-slip in barefoot areas*
-  *Frostproof in acc. with DIN EN ISO 10545-12*
-  *Rectified*
-  *Precious metal-plated. Not scratchproof. Clean with water or dish washing liquid only. Use only a suitable, fine-grain mortar with low quartz content for jointing.*
-  *Tile thickness 20 mm*
-  *Tile thickness 6 mm*
-  **ceramicplus**
-  **vilbostoneplus** *Surface seal*
-  **PowderTouch** *Matt, powdery premium glaze*
-  **concept<sup>3</sup>** *Complete wall and floor concept*
-  **1 2 3 4** *Shade variation*



Villeroy & Boch

1748

SECTION



Wand- und Bodenfliesen | *Wall and floor tiles: SECTION creme-weiß | creme-white*



# Produktübersicht | *Product overview*

## Grundfliesen aus Feinsteinzeug Porcelain stoneware basic tiles

**vilbostone**  
Feinsteinzeug · Porcelain stoneware

**vilbostoneplus**

60 x 60 cm  
creme-weiß  
creme-white



R9



sandbeige  
sandbeige



R9



zementgrau  
cement grey



R9



anthrazit  
anthracite



R9



30 x 50 cm



R9

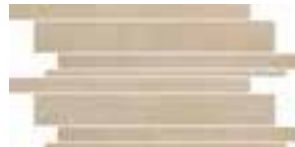

R9



R9



R9

30 x 60 cm



R9

5 x 5 cm

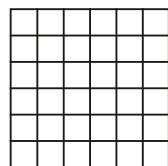

R10 B

7,5 x 60 cm



Sockel  
Skirting

Grundfliesen in allen Farben erhältlich · Basic tiles available in all colours

### Zeichenschlüssel | *Signs and symbols*

**vilbostoneplus** = Oberflächenversiegelung  
*Surface seal*

= Frostbeständig nach DIN EN 10545-12  
*Frostproof in acc. with DIN EN 10545-12*

= Rektifiziert · *Rectified*

R9 = Rutschhemmung im gewerblichen Bereich  
*Anti-slip in workshop areas*

R10 = Rutschhemmung im gewerblichen Bereich  
*Anti-slip in workshop areas*

B = Rutschhemmung im Barfußbereich  
*Anti-slip in barefoot areas*

= Variationsvielfalt · *Shade variation*



## SECTION – Das Wohnambiente der modernen Art

Keramikfliesen mit einer schlichten Betonanmutung vermitteln ein zeitlos urbanes Flair, das sich unmittelbar auf den Raum überträgt. Die vilbostone Feinsteinzeugserie SECTION zeigt dies in attraktivem Creme-weiß, natürlichem Sandbeige, in Zementgrau und Anthrazit. Alle Farben der modularen Formate 60 x 60 cm und 30 x 60 cm sind harmonisch aufeinander abgestimmt und kombinierbar. Die Stäbchenmatte kann im Vollformat 30 x 50 cm als moderne Wanddekoration oder im halben Format 15 x 50 cm als stilvolle Bordüre eingesetzt werden. Das Mosaik im Format 5 x 5 cm eignet sich neben der dekorativen Verwendung vor allem für die Gestaltung von bodenebenen Duschen.

## SECTION – *A modern living environment*

*Ceramic tiles with a plain concrete look convey timeless urban flair that is transferred directly to the surrounding space – as exemplified by the SECTION vilbostone porcelain stoneware range in attractive creme-white, natural sandbeige, cement grey and anthracite. All the colours, available in the modular 60 x 60 cm and 30 x 60 cm formats, are coordinated and can be combined. The rod mats can be used in the full 30 x 50 cm format as modern wall decorations or in the half 15 x 50 cm format as stylish borders. The 5 x 5 cm mosaic are ideal as a decorative element and particularly suitable for walk-in showers.*

## **vilbostone**<sup>plus</sup>

Das unglasierte vilbostone Feinsteinzeug ist in matter und anpolierter Ausführung mit der Oberflächenversiegelung vilbostone**plus** ausgestattet, das die Fliesen unempfindlich gegen Schmutz und Flecken macht. Während des Herstellungsprozesses der Fliesen wird die Struktur ihrer Oberflächen so versiegelt, dass die Fleck- und Schmutzbeständigkeit weiter zunimmt und eine Nachbehandlung mit Imprägniermitteln nicht mehr erforderlich ist.

*Unglazed vilbostone porcelain stoneware with a matt or rough-polished surface finish have the vilbostone**plus** seal, which renders the tiles particularly resistant to dirt and stains. During the manufacturing process, the structure of the tile surface is sealed in order to further increase the tiles' resistance to staining and dirt, as a result of which subsequent treatment with impregnating agents is no longer necessary.*



HUDSON









Faszinierend natürlich – eine Keramik, die zum Anfassen animiert. Die unglasierten Oberflächen der vilbostone Feinsteinzeugfliesen HUDSON erinnern unwillkürlich an feinkörnigen Sand. Fünf naturnahe, dezent schattierte Farben erzeugen in Räumen behagliche und zugleich puristische Stimmungen. Zur Wahl stehen die warmtonig hellen Farben white sand, sand und clay sowie die dunkleren, etwas kühler anmutenden Farbtöne volcano und magma.

Fascinatingly natural – ceramics that just ask to be touched. The unglazed surfaces of the HUDSON range of vilbostone porcelain stoneware tiles are reminiscent of fine-grained sand. Five natural, subtly shaded colours lend rooms a cosy and at the same time minimalist mood. Choose from the warm, bright colours white sand, sand and clay as well as the deeper, slightly cooler hues of volcano and magma.

Une céramique naturelle et fascinante que l'on a envie de toucher. La surface non émaillée des carreaux en grès cérame porcelainé vilbostone HUDSON évoque spontanément la structure du sable fin.

Cinq couleurs naturelles et subtilement ombrées créent dans les pièces des ambiances à la fois cosy et épurées. Cette série propose au choix les couleurs chaudes et claires white sand, sand et clay ainsi que les nuances plus sombres et légèrement plus froides volcano et magma.



**reddot design award**  
winner 2018

Die Designqualität der Serie HUDSON wurde mit dem „red dot award: product design 2018“ ausgezeichnet.

The HUDSON range was presented with the “red dot award: product design 2018” for its impressive design quality.

En raison de la qualité de son design, la série HUDSON vient de recevoir le prix « red dot award : product design 2018 ».

Funktionale und ästhetische Vielseitigkeit ist grundlegend für das Konzept der Serie HUDSON. Dies zeigt sich schon bei den unterschiedlichen Oberflächenvarianten und deren Anwendungsvorteilen. So sind die Fliesen mit anpolierter Oberfläche in den Formaten 30 x 60 cm und 60 x 60 cm mit der Trittsicherheitsklasse R9 ausgestattet. Mindestens die Trittsicherheitsklasse R10/A weisen alle Fliesen mit matten Oberflächen auf. Außerdem sind die Formate 30 x 60 cm und 60 x 60 cm mit der Trittsicherheitsklasse R10/B verfügbar.

Functional and aesthetic versatility is fundamental to the concept of the HUDSON range. This is already evident in the different surface finishes and their practical advantages.

For example, the tiles with a rough-polished finish, in the formats 30 x 60 cm and 60 x 60 cm, feature slip-resistance class R9. All of the tiles with matt finishes offer a slip-resistance class of at least R10/A. The 30 x 60 cm and 60 x 60 cm formats are also available in slip-resistance class R10/B.

La polyvalence fonctionnelle et esthétique est à la base du concept de la série HUDSON. Ceci est déjà évident dans les différentes finitions et les avantages qu'elles présentent au niveau des applications.

Ainsi, les carreaux surfacés déclinés dans les formats 30 x 60 cm et 60 x 60 cm sont antidérapants en catégorie R9. Les carreaux mats sont tous au minimum classés en classe antidérapante R10/A. Les formats 30 x 60 cm et 60 x 60 cm sont en outre disponibles en catégorie antidérapante R10/B.





Für Sicherheit beim Barfußgehen in Dauernassbereichen sorgen die Formate 15 x 15 cm, 30 x 30 cm und 30 x 60 cm mit der Trittsicherheitsklasse R11/C.

Doch nicht nur in öffentlichen Bereichen, sondern auch in Wohn- und Geschäftsräumen regt das vielfältige, modulare System zu kreativen Verlegungen an.

Mit insgesamt neun Formaten – von der sehr schmalen Fliese im Format 7,5 x 60 cm über das Mosaik in 7,5 x 7,5 cm bis zum quadratischen oder rechteckigen Großformat sowie zusätzlich einem dekorativen Stäbchenmosaik und einer Treppenfliese – erlaubt HUDSON unzählige Kombinationsmöglichkeiten.

With the slip-resistance class R11/C, the 15 x 15 cm, 30 x 30 cm and 30 x 60 cm formats ensure barefoot safety in wet areas.

The versatile, modular system inspires creative layouts not just in public areas but in residential and business spaces, too.

With nine formats in all – from the very narrow 7.5 x 60 cm tile to the mosaic in 7.5 x 7.5 cm or the square or rectangular large formats as well as a decorative mosaic strip tile and a stair tile – HUDSON offers countless combination options.

Classés en catégorie antidérapante R11/C, les formats 15 x 15 cm, 30 x 30 cm et 30 x 60 cm assurent la sécurité de la marche pieds nus dans les zones constamment soumises à l'humidité.

Le système modulaire polyvalent invite à réaliser des revêtements créatifs non seulement dans les espaces publics, mais aussi dans les locaux résidentiels et commerciaux. Avec ses neuf formats, la série HUDSON permet de réaliser une infinité de combinaisons : depuis le carreau très étroit en 7,5 x 60 cm jusqu'aux grands formats carrés ou rectangulaires en passant par la mosaïque 7,5 x 7,5 cm ainsi qu'une mosaïque décorative formée de baguettes et des marches d'escalier.











#### HUDSON OPTIMA

– überdimensionale Größe vereint mit urbanem Flair. Die nur 6 mm dicken Fliesen sind in den Formaten 60 x 120 cm, 120 x 120 cm und 120 x 260 cm ein Highlight für jede Raumgestaltung.

Nicht nur in der Renovation werden die Megaformate aufgrund ihres vergleichsweise geringen Gewichts und der geringen Aufbauhöhe geschätzt. Mit einer Höhe von bis zu 260 cm sind sie optimal auf Raumhöhen angepasst. Der geringe Fugenteil sorgt für eine großzügige, puristische Wirkung und erleichtert die Reinigung und Pflege des Belags.

#### HUDSON OPTIMA

– oversized dimensions combined with urban flair. In formats of 60 x 120 cm, 120 x 120 cm and 120 x 260 cm, these tiles, just 6 mm thick, are a highlight for any interior design.

These megaformats are not only perfect for renovations thanks to their relatively low weight and low overall height. With lengths of up to 260 cm, they are optimally adapted to room heights. Surfaces with few joints have a generous and minimalist effect; the tiling is also much easier to clean and care for.

#### HUDSON OPTIMA

– des carreaux surdimensionnés pour un style citadin. Ces carreaux très minces de seulement 6 mm d'épaisseur sont proposés dans les formats 60 x 120 cm, 120 x 120 cm et 120 x 260 cm, parfaits pour tout l'intérieur de la maison.

Les très grands formats ne sont pas uniquement appréciés dans la rénovation en raison de leur poids relativement bas et de leur faible épaisseur. Avec une longueur allant jusqu'à 260 cm, ils sont parfaitement adaptés à la hauteur normale des pièces. La faible proportion de joints garantit une esthétique généreuse et épurée tout en facilitant le nettoyage et l'entretien du revêtement.

# Produktübersicht | Product overview | Tableau récapitulatif des produits

Grundfliesen aus Feinsteinzeug (für Wand und Boden geeignet)  
 Porcelain stoneware basic tiles (suitable for walls and floors)  
 Carreaux de fond en grès cérame porcelainé (pour sol et mur)

**vilbostone**plus

**vilbostone**  
 Feinsteinzeug · Porcelain stoneware  
 Grès cérame porcelainé

Art. 2987 · 60 x 120 cm  
 white sand



SD1B 2

sand



SD2B 2

clay



SD7B 2

volcano



SD9B 2

magma



SD8B 2

Art. 2988  
 30 x 120 cm

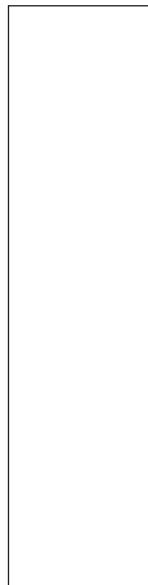

SD1B · SD2B · SD7B  
 SD9B · SD8B

Art. 2732  
 30 x 120 cm

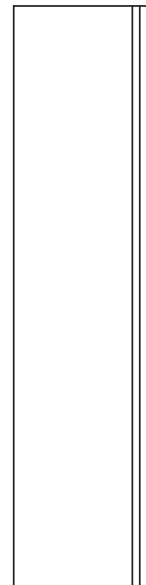

SD1B · SD2B · SD7B  
 SD9B · SD8B

Treppenauftritt  
 Stair tread  
 Marche d'escalier

\* = Auftragsbezogene Fertigung. Mindestbestellmenge 100 m<sup>2</sup>.  
 Lieferzeit auf Anfrage.  
 Custom-made production. Minimum order quantity 100 m<sup>2</sup>.  
 Delivery time on request.  
 Fabrication sur demande. La quantité minimum est de 100 m<sup>2</sup>.  
 Délai de livraison sur demande.

**Grundfliesen aus Feinsteinzeug (für Wand und Boden geeignet)**  
**Porcelain stoneware basic tiles (suitable for walls and floors)**  
**Carreaux de fond en grès cérame porcelainé (pour sol et mur)**

Art. 2577  
60 x 60 cm

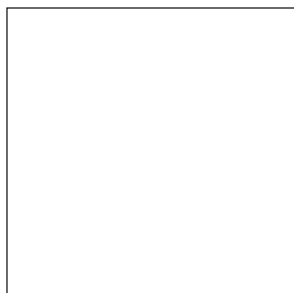

SD1B · SD2B · SD7B  
SD9B · SD8B  
✳️ / 90° R10 A  
SD1M · SD2M · SD7M  
SD9M · SD8M  
✳️ / 90° R10 B

Art. 2577  
60 x 60 cm

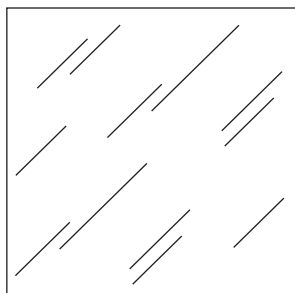

SD1L · SD2L · SD7L  
SD9L · SD8L  
✳️ / 90° R9

Art. 2419  
15 x 60 cm\*



SD1B · SD2B · SD7B  
SD9B · SD8B  
✳️ / 90° R10 A

Art. 2569  
15 x 15 cm\*



SD1M · SD2M · SD7M  
SD9M · SD8M  
✳️ / 90° R10 B

Art. 2852  
7,5 x 60 cm\*



SD1B · SD2B · SD7B  
SD9B · SD8B  
✳️ / 90° R10 A

Art. 2519  
15 x 15 cm\*



SD1R · SD2R · SD7R  
SD9R · SD8R  
✳️ / 90° R11 B

Art. 2576  
30 x 60 cm



SD1B · SD2B · SD7B  
SD9B · SD8B  
✳️ / 90° R10 A  
SD1M · SD2M · SD7M  
SD9M · SD8M  
✳️ / 90° R10 B

Art. 2576  
30 x 60 cm

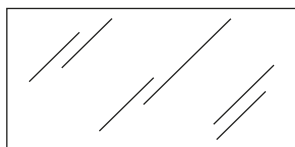

SD1L · SD2L · SD7L  
SD9L · SD8L  
✳️ / 90° R9

Art. 2526  
30 x 60 cm\*

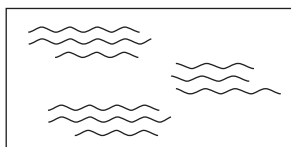

SD1R · SD2R · SD7R  
SD9R · SD8R  
✳️ / 90° R11 C

Art. 2872  
7,5 x 60 cm

Sockel  
Skirting  
Plinthe

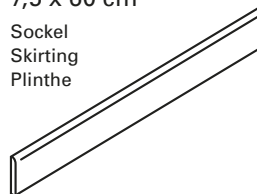

SD1B · SD2B · SD7B  
SD9B · SD8B  
✳️ / 90°

Art. 2575  
30 x 30 cm\*



SD1M · SD2M · SD7M  
SD9M · SD8M  
✳️ / 90° R10 B

Art. 2525  
30 x 30 cm\*

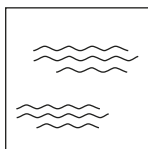

SD1R · SD2R · SD7R  
SD9R · SD8R  
✳️ / 90° R11 C

Art. 2013  
7,5 x 7,5 cm

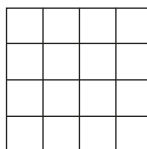

SD1B · SD2B · SD7B  
SD9B · SD8B  
✳️ / 90° R10 B

Art. 2135  
2,5 x 15 cm

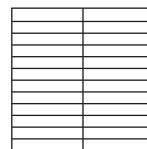

SD1B · SD2B · SD7B  
SD9B · SD8B  
✳️ / 90° R10 B

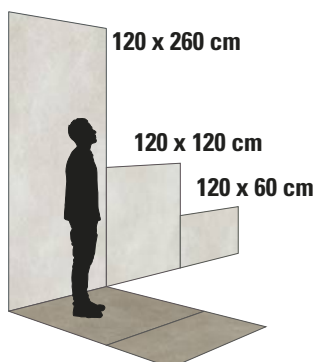

OPTIMA: auch in den Formaten 60 x 120, 120 x 120 und 120 x 260 cm in 6 mm erhältlich.  
 OPTIMA: also available in the formats 60 x 120, 120 x 120 and 120 x 260 cm in 6 mm thickness.  
 OPTIMA : également disponible dans les formats 60 x 120, 120 x 120 et 120 x 260 cm en 6 mm d'épaisseur.

Variationsvielfalt | Shade variation | Variation chromatique



60 x 60 cm | white sand



60 x 60 cm | sand



60 x 60 cm | clay







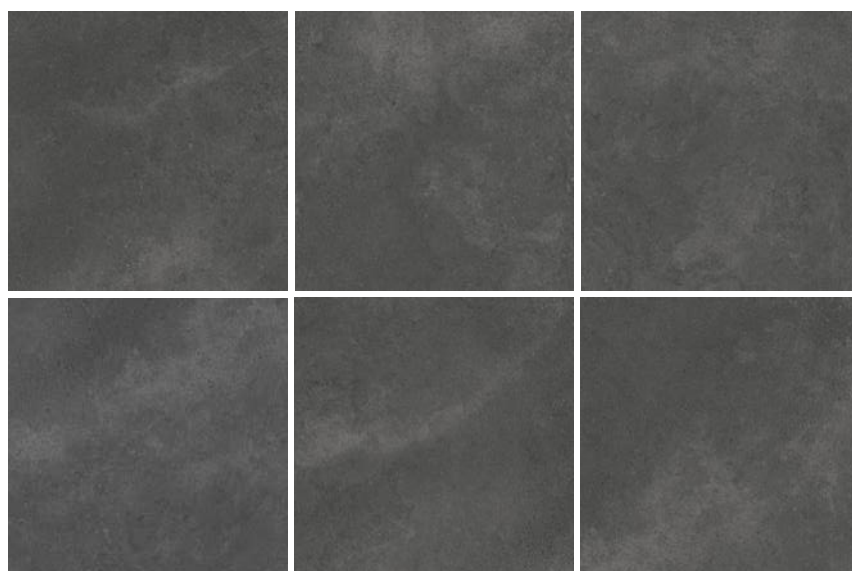









60 x 60 cm | volcano



60 x 60 cm | magma



#### Zeichenschlüssel | Signs and symbols | Légende des symboles

- |  |   |
|--|---|
| <ul style="list-style-type: none"> <li> = Rektifiziert   Rectified   Rectifié</li> <li> = Frostbeständig   Frostproof   Non gélif<br/>(EN ISO 10545-12)</li> <li> R9 = Rutschhemmung im gewerblichen Bereich</li> <li> R10 = Anti-slip in workshop areas</li> <li> R11 = Propriétés antidérapantes dans les domaines industriels</li> </ul> | <ul style="list-style-type: none"> <li> A = Rutschhemmung im Barfußbereich</li> <li> B = Anti-slip in barefoot areas</li> <li> C = Propriétés antidérapantes dans les zones pieds nus</li> <li> 6 = Fliesenstärke 6 mm   Tile thickness 6 mm<br/>Épaisseur des carreaux 6 mm</li> <li> 1  2  3  4 = Variationsvielfalt   Shade variation<br/>Variation chromatique</li> </ul> |
|--|---|





CÁDIZ









Die in vielfacher Weise in der Innenarchitektur adaptierten Naturmaterialien und Oberflächen schaffen authentische Ursprünglichkeit in Wohn- und Arbeitsbereichen. Beim Fliesenkonzept CÁDIZ offenbaren die Oberflächen der hochwertigen vilbostone Bodenfliesen einen besonderen Charakter – lebhaft, aber nicht aufdringlich – wie prachtvolle Ausschnitte aus der Natur. Harmonisch ergänzt werden die naturnahen Bodenfliesen durch Wandfliesen aus Steingut, die ein helles behagliches Flair verbreiten.

The natural materials and finishes have been adapted in a variety of ways for interior design to create an authentic originality in living and working areas. The surfaces of the high quality vilbostone floor tiles in the CÁDIZ tile concept reveal a very special character – lively, yet not intrusive – like magnificent extracts from Nature herself. These natural floor tiles are complemented by nonvitreous wall tiles that create a bright and comfortable atmosphere.

Les matériaux naturels et les surfaces adaptés à l'architecture d'intérieur font entrer l'authenticité dans les pièces à vivre et les zones de travail. Le concept de carreaux CÁDIZ avec sa finition de carreaux de sol en grès cérame porcelainé vilbostone haut de gamme, les carreaux affichent un caractère exceptionnel, intense mais discret, comme de somptueuses découpes de la nature. Les carreaux de sol proches de la nature sont harmonieusement complétés par des carreaux muraux en faïence qui répandent une ambiance confortable.

Großformatige Bodenfliesen im Duschbereich sind nicht nur elegant, sondern durch den geringen Fugenanteil auch besonders reinigungsfreundlich. Die Serie CÁDIZ im Format 30 x 60 cm ist mit der Trittsicherheitsklasse R10/B eine sichere Variante, bodengleiche Duschen modern zu gestalten.

Large-format floor tiles in the showering area are not only elegant, but their small number of joints means they are also very easy to clean. The CÁDIZ tile range in format 30 x 60 cm, with slip-resistance class R10/B, is a safe variant for modern floor-level showers.

Les carreaux de solo grands formats dans la douche ne se contentent pas d'être élégants ; ils sont aussi particulièrement faciles à entretenir en raison de leur faible proportion de joints. Classée en catégorie antidérapante R10/B, la série CÁDIZ en 30 x 60 cm est parfaitement adaptée aux revêtements modernes de douches à l'italienne.











Erhältlich auch als OUTDOOR TILES in den Farben Chalk Multicolor, Sand und Grey Multicolor mit einer erhöhten Stärke von 20 mm für Balkone und Terrassen, präsentiert sich die Serie CÁDIZ als zeitgemäße Interpretation des Landhausstils sowohl für Innen- als auch für Außenbereiche: Die pflegeleichte *vilbostone* Feinsteinzeugserie ist im quadratischen Großformat 60 x 60 ebenso wie im eleganten Rechteckformat 40 x 80 cm ein umfassendes Konzept, das in Stadtwohnungen genauso angesagt ist wie im ländlichen Ambiente.

Available as OUTDOOR TILES in the colours chalk multicolor, sand and grey multicolor with an increased thickness of 20 mm for balcony and terrace floors, the CÁDIZ range is the contemporary interpretation of country-house style for use both indoors and out: the easy-care *vilbostone* porcelain stoneware, available in the large square format 60 x 60 cm and the elegant rectangular format 40 x 80 cm, is an extensive tile concept that is just as popular in city flats as it is in a rural setting.

Également disponible en version OUTDOOR TILES pour l'extérieur en épaisseur de 20 mm pour les balcons et les terrasses et dans les coloris chalk multicolor, sand et grey multicolor, la série CÁDIZ est une interprétation contemporaine du style campagnard aussi bien pour l'intérieur que pour l'extérieur de la maison. Facile à entretenir, cette série en grès cérame porcelainé est un concept complet proposé dans le format carré 60 x 60 cm et dans un élégant format rectangulaire en 40 x 80 cm qui convient autant aux appartements urbains qu'aux environnements campagnards.







# Produktübersicht | Product overview | Tableau récapitulatif des produits

Grundfliesen aus Feinsteinzeug (für Wand und Boden geeignet)  
 Porcelain stoneware basic tiles (suitable for walls and floors)  
 Carreaux de fond en grès cérame porcelainé (pour sol et mur)



Art. 2812 · 80 x 80 cm  
 chalk multicolor



BU1M   
  R10 A  
 BU1L  
 R9

chalk



BU0M   
  R10 A  
 BU0L  
 R9

sand



BU2M   
  R10 A  
 BU2L  
 R9

grey multicolor



BU7M   
  R10 A  
 BU7L  
 R9



ash grey



BU9M   
  R10 A  
 BU9L  
 R9



Art. 2842  
 40 x 80 cm

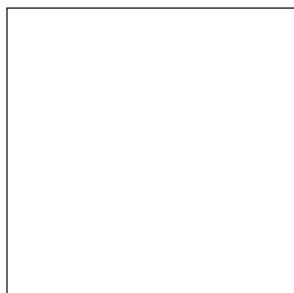

BU1M · BU0M · BU2M  
 BU7M · BU9M  
  R10 A  
 BU1L · BU0L · BU2L  
 BU7L · BU9L  
 R9

Art. 2570  
 60 x 60 cm



BU1M · BU0M · BU2M  
 BU7M · BU9M  
  R10 A  
 BU1L · BU0L · BU2L  
 BU7L · BU9L  
 R9



Art. 2572  
 30 x 60 cm



BU1M · BU0M · BU2M  
 BU7M · BU9M  
  R10 A  
 BU1L · BU0L · BU2L  
 BU7L · BU9L  
 R9

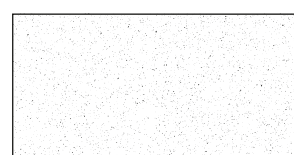

Art. 2685<sup>1)</sup>  
 30 x 60 cm

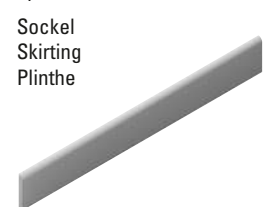

BU1M · BU0M · BU2M  
 BU7M · BU9M  
  R10 B

Art. 2872  
 7,5 x 60 cm



Socket  
 Skirting  
 Plinthe  
 BU7M · BU9M  
 BU0M · BU1M · BU2M  
 

**Grundfliesen aus Steingut (nur für die Wand geeignet)**  
**Nonvitreous basic tiles (suitable for walls only)**  
**Carreaux de fond en faïence (uniquement pour les murs)**

Art. 1310 · 30 x 90 cm  
 chalk



BU00

Art. 1581 · 30 x 60 cm  
 chalk



BU00

**Grundfliesen aus Feinsteinzeug (für Wand und Boden geeignet)**  
**Porcelain stoneware basic tiles (suitable for walls and floors)**  
**Carreaux de fond en grès cérame porcelainé (pour sol et mur)**



Art. 2496 · 10 x 20 cm  
 chalk multicolor



BU1M  
  
 BU1L

chalk



BU0M  
  
 BU0L

grey multicolor



BU7M  
  
 BU7L

ash grey



BU9M  
  
 BU9L

sand



BU2M  
  
 BU2L

Art. 2037 · 5 x 10 cm  
 chalk multicolor



BU1M

chalk



BU0M

grey multicolor



BU7M

ash grey



BU9M

sand



BU2M

**Zeichenschlüssel | Signs and symbols | Légende des symboles**

= Rektifiziert | Rectified | Rectifié

= Frostbeständig | Frostproof | Non gélif  
 (EN ISO 10545-12)

1) = Auftragsbezogene Fertigung. Mindestbestellmenge 100 m<sup>2</sup>.  
 Lieferzeit ca. 6 Wochen ab AE.  
 Custom-made production. Minimum order quantity 100 m<sup>2</sup>.  
 Delivery time about 6 weeks after receipt of order.  
 Fabrication sur demande. La quantité minimum est de 100 m<sup>2</sup>.  
 Délai de livraison environ 6 semaines après commande.

= Rutschhemmung im gewerblichen Bereich  
 Anti-slip in workshop areas  
 Propriétés antidérapantes dans les domaines industriels

= Rutschhemmung im Barfußbereich  
 Anti-slip in barefoot areas  
 Propriétés antidérapantes dans les zones pieds nus

= Fliesenstärke 20 mm | Tile thickness 20 mm  
 Épaisseur des carreaux 20 mm

= Variationsvielfalt | Shade variation  
 Variation chromatique

# Produktübersicht | Product overview | Tableau récapitulatif des produits

Grundfliesen aus Feinsteinzeug | Porcelain stoneware basic tiles  
Carreaux de fond en grès cérame porcelainé

**vilbostone**plus

**vilbostone**  
Feinsteinzeug · Porcelain stoneware  
Grès cérame porcelainé

## CÁDIZ OUTDOOR

Art. 2803 · 60 x 60 cm  
sand



BU2M 3

chalk multicolor



BU1M 3

grey multicolor



BU7M 4

Art. 2807 · 40 x 80 cm  
sand



BU2M 3

chalk multicolor



BU1M 3

grey multicolor



BU7M 4

## Variationsvielfalt | Shade variation | Variation chromatique



 3 chalk multicolor

 3 chalk



 4 grey multicolor

 3 ash grey



 3 sand

The STAGEART wall and floor concept by Tiles stands for clear minimalism with a natural touch. This makes it perfect for anyone with an interest in contemporary art and lifestyle seeking to bring a fine, natural flair into their rather minimalist home. This is because, with a fresh design composition of cement and stone structures and a subtle, graphic relief décor, STAGEART offers new, individual design options for the trendy look of concrete.

STAGEART includes wall tiles made of nonvitreous and **VilboStone** porcelain stoneware that can be used on walls and floors. The wall tiles in creme and light grey are simply matt and smooth. The matching décor tiles feature slight hints of cubist relief patterns with a very subtle artistic effect. Perfectly coordinated with this: Porcelain stoneware tiles in the four expressive colours of dust, silver, iron and rust that accentuate the design structure a little more.

Good to know: With R10/B, slip resistance, these porcelain stoneware tiles offer such safe traction that even the large formats of 30 x 60 and 60 x 60 cm can be laid safely in the shower area – for high levels of aesthetic appeal and functionally at the same time.

---







# URBAN ART









## Die Backsteinkultur großstädtischer Lofts

– ein innenarchitektonischer Stil, der nie an Aktualität eingebüßt hat. URBAN ART aus glasiertem Feinsteinzeug veredelt diesen Trend mit glänzenden Oberflächen in sechs verschiedenen Farben. Gestaltet im typischen Brickformat in 6 x 25 cm, ergänzt um ein Mosaik in 10 x 10 cm, setzt die Serie ein Statement in Wohnräumen, Bädern und in öffentlichen Bereichen. Ähnlich wie die historischen Vorbilder zeigen die Fliesen leichte Farbverläufe und weisen eine hohe Variationsvielfalt innerhalb der Farbe auf. Betont wird die handwerklich anmutende Ausstrahlung noch durch die unregelmäßigen Kanten, so dass auch das Fugenbild das typische Erscheinungsbild trägt. Bestehend aus glasiertem Feinsteinzeug sind die Wandfliesen URBAN ART auch für Nassbereiche in öffentlichen Anwendungsbereichen bestens geeignet.

## The brick culture of metropolitan lofts

– an interior design style that has never gone out of fashion. Made of glazed porcelain stoneware, URBAN ART enriches this trend with glossy finishes in six different colours. Designed in the typical brick format of 6 x 25 cm and supplemented by a 10 x 10 cm mosaic, this range creates a statement in living rooms, bathrooms and public spaces. Like the historic models on which they are based, these tiles show slight gradations of colour and present a wide variety of variations within a particular colour. The appearance of craftsmanship is emphasised through irregular edging to give the joint pattern a typical appearance. Made of glazed porcelain stoneware, URBAN ART wall tiles are also perfectly suited for use in wet areas in public buildings.

## La culture de la brique dans les lofts des grandes villes



















– un style d'architecture d'intérieur qui n'a jamais rien perdu de son actualité. URBAN ART en grès cérame porcelainé émaillé perfectionne cette tendance en proposant des surfaces brillantes en six couleurs différentes. Conçue dans le format 6 x 25 cm typique pour les briques et complétée par une mosaïque de 10 x 10 cm, cette série est parfaite pour les pièces à vivre, les salles de bains et les espaces publics. À l'instar des modèles historiques, ces carreaux présentent de légers dégradés de couleurs ainsi qu'une grande diversité à l'intérieur de chaque couleur. Le look artisanal des carreaux est encore accentué par l'irrégularité de leurs chants si bien que les joints présentent eux aussi cette esthétique caractéristique. Étant fabriqués en grès cérame porcelainé émaillé, les carreaux muraux de la série URBAN ART sont également parfaitement adaptés aux zones humides dans les espaces publics.

# URBAN ART



**Grundfliesen aus glasiertem Feinsteinzeug (nur für die Wand geeignet)**  
**Glazed porcelain stoneware basic tiles (suitable for walls only)**  
**Carreaux de fond en grès cérame porcelainé émaillé (uniquement pour les murs)**





VilboStone

Art. 2682 · 6 x 25 cm

white	mustard	moss green	cobalt	red	tobacco
					
UA00  3	UA20  3	UA50  3	UA40  3	UA30  3	UA70  3
					

Art. 2190 · 10 x 10 cm

white	mustard	moss green	cobalt	red	tobacco
					
UA00  3	UA20  3	UA50  3	UA40  3	UA30  3	UA70  3
					

 = Frostbeständig · Frostproof  
 Non gélif · DIN EN ISO 10545-12  
1 2 3 4 = Variationsvielfalt · Shade variation  
 Variation chromatique



Bodenfliesen | Floor tiles | Carreaux de sol : CODE 2 porfid

Wandfliesen | Wall tiles | Carreaux de mur : CODE 2 honey, URBAN ART white

# URBAN ART

Variationsvielfalt | Shade variation | Variation chromatique



white

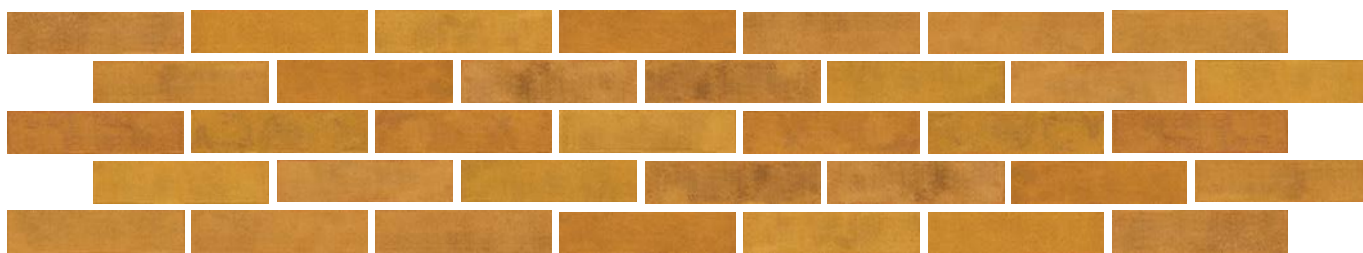

mustard

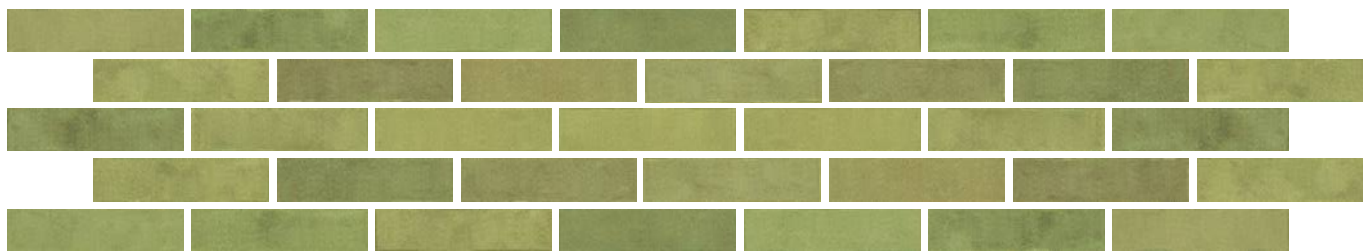

moss green

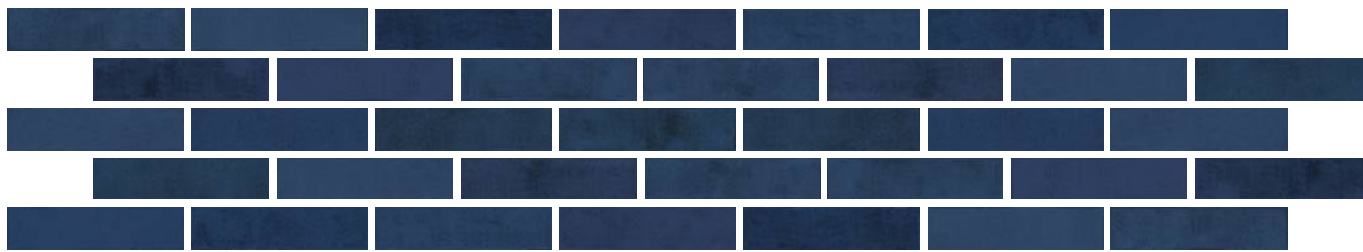

cobalt

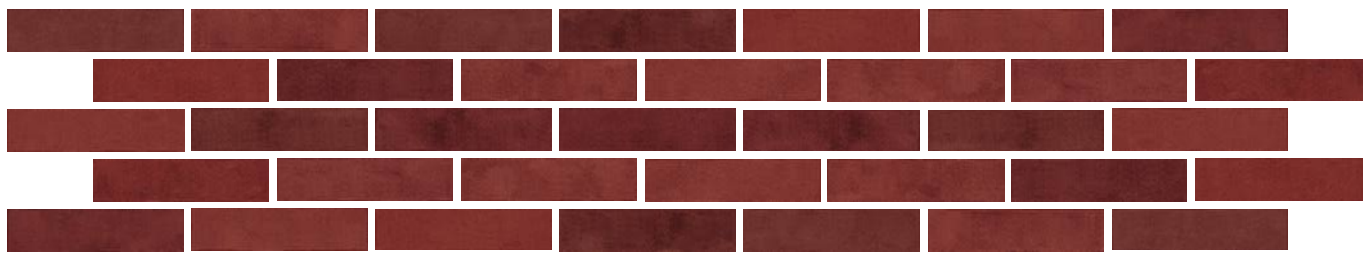

red

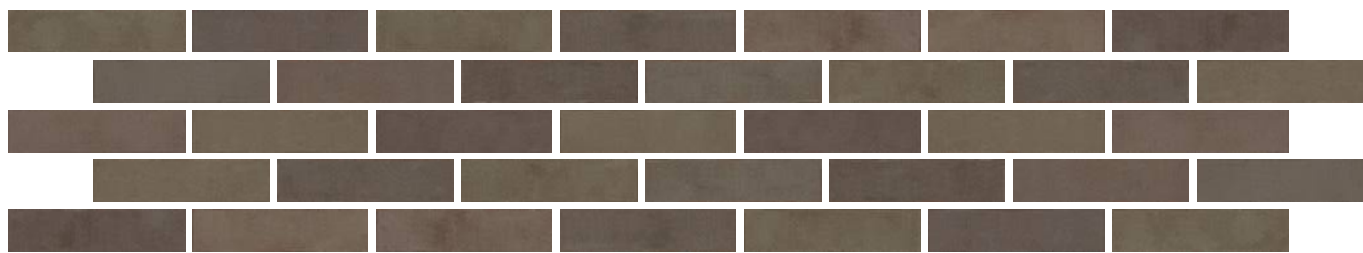

tobacco





CODE 2



## Natürliche Vielfalt für kreative Raumgestaltungen

– die **VilboStone** Feinsteinzeugserie CODE 2 eröffnet ein Spiel der Möglichkeiten. Mit zwei Farbrichtungen in jeweils drei Steinoptiken sowie zwei Holzanmutungen inspiriert die Kollektion zu abwechslungsreichen Verlegungen. Durch die Großzügigkeit der Formate fällt der Fugenanteil sehr gering aus – ein Vorteil, der für zusätzliche Pflegeleichtigkeit spricht. Dafür sorgt auch die Oberflächenaustrüstung **VilbostonePlus**, die die Fleck- und Schmutzempfindlichkeit deutlich reduziert.

## Natural variety for creative room designs

– CODE 2, the **VilboStone** porcelain stoneware range opens up an entire range of possibilities. With two colour schemes in three stone looks and two wood looks each, this collection is an inspiration to multi-faceted tiling arrangements. These generously dimensioned formats mean a minimal proportion of joints – an advantage that speaks for additional ease of care. This is also ensured by the **VilbostonePlus** surface texture, which significantly reduces the tiles' susceptibility to staining and soiling.

## Une diversité naturelle pour des aménagements créatifs

– la série CODE 2 en grés cérame porcelainé **VilboStone** offre une foule de possibilités. Avec deux lignes de couleurs déclinées sur trois looks de pierre et deux imitations bois, cette collection permet de réaliser des revêtements variés. Les grandes dimensions des carreaux diminuent fortement la proportion de joints ce qui présente un avantage supplémentaire au niveau de l'entretien. Y contribue également le traitement **VilbostonePlus** qui réduit considérablement la sensibilité des carreaux aux taches et aux salissures.







Bodenfliesen | Floor tiles | Carreaux de sol : CODE 2 stone



Gestaltungen in Objekt- und Privatbereichen sind mit CODE 2 fein aufeinander abgestimmt und dennoch individuell bis ins Detail. Die Serie ist in privaten Küchen und Bädern, genauso wie in Hotels, Geschäften oder Gastronomiebereichen eine Bereicherung für die Innenarchitektur. Für ästhetische und funktionale Gestaltungen gehören zu jeder der Steinoptiken Treppenfliesen mit gerundeter Stufenvorderkante und gefrästen Rillen sowie Mosaik und Sockel.

With CODE 2, designs in commercial and private areas are finely coordinated yet individual down to the details. This range is an enrichment for interior design – in private kitchens and bathrooms, and in hotels, shops or restaurants as well. For aesthetically appealing and functional designs, each of the stone looks features stair tiles with rounded-front stair nosing and milled grooves, as well as mosaics and strip skirting.

La série CODE 2 permet de parfaitement coordonner jusque dans les moindres détails les aménagements dans les espaces collectifs et privés. Cette série est un enrichissement pour l'architecture d'intérieur dans les cuisines et les salles de bains privées ainsi que dans les hôtels, les commerces ou encore les restaurants. Pour réaliser des aménagements esthétiques et fonctionnels, chacun des looks de pierre comprend des marches d'escalier avec des bords d'attaque arrondis et des rainures fraisées ainsi que des mosaïques et des plinthes.

# CODE 2

**Grundfliesen aus Feinsteinzeug (für Wand und Boden geeignet)**  
**Porcelain stoneware basic tiles (suitable for walls and floors)**  
**Carreaux de fond en grès cérame porcelainé (pour sols et murs)**

Art. 2730 · 60 x 120 cm  
porfid



SN70 A  
stone

ceppo light



SN71 A  
rock light

ceppo dark



SN72 A  
rock dark



SN60 A



SN61 A

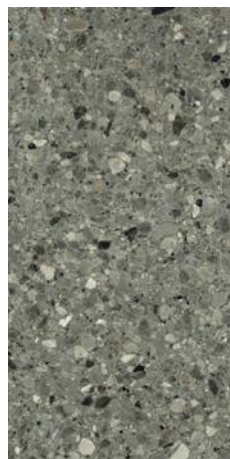

SN62 A

Art. 2810  
80 x 80 cm

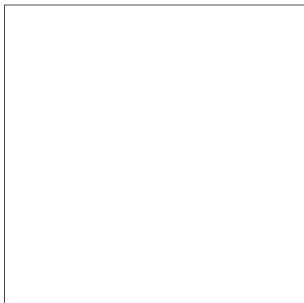

SN70 · SN71 · SN72  
SN60 · SN61 · SN62  
 A

Art. 2660  
60 x 60 cm

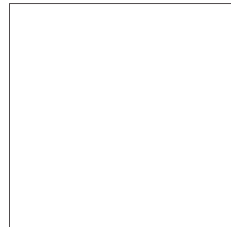

SN70 · SN71 · SN72  
SN60 · SN61 · SN62  
 A

Art. 2013  
7,5 x 7,5 cm

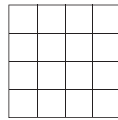

SN70 · SN71 · SN72  
SN60 · SN61 · SN62  
 A

Art. 2875  
5 x 60 cm

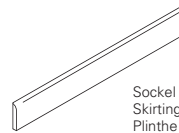

SN70 · SN71 · SN72  
SN60 · SN61 · SN62

Art. 2795 · 20 x 120 cm  
natural



SN80

honey



SN20

**VilboStone**  
**VilbostonePlus**

Art. 2732  
30 x 120 cm

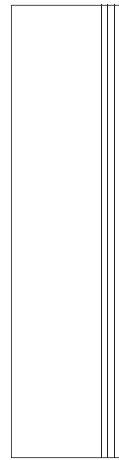

Treppenauftritt  
Stair tread  
Marche d'escalier

SN70 · SN71 · SN72  
SN60 · SN61 · SN62  
 A

= Rektifiziert · Rectified · Rectifié  
 = Frostbeständig · Frostproof  
Non gélif DIN EN ISO 10545-12

R10 = Rutschhemmung im gewerblichen Bereich  
Anti-slip in workshop areas  
Propriétés antidérapantes dans les domaines industriels

A = Rutschhemmung im Barfußbereich  
Anti-slip in barefoot areas  
Propriétés antidérapantes dans les zones pieds nus

= Variationsvielfalt · Shade variation  
Variation chromatique

# CODE 2

Variationsvielfalt | Shade variation | Variation chromatique



porfid 

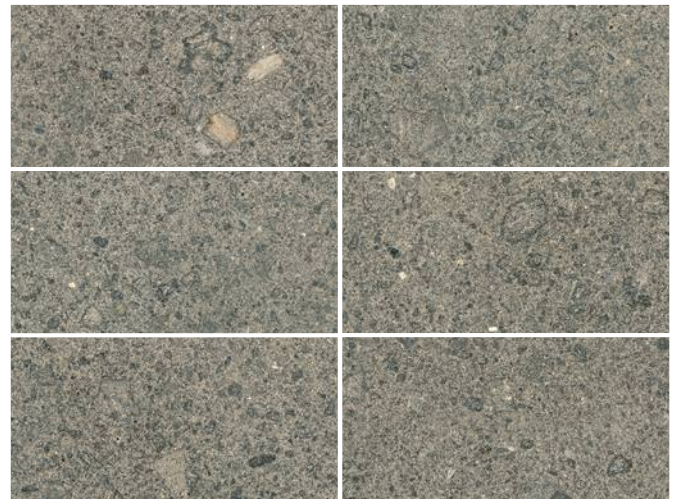

stone 



ceppo light 

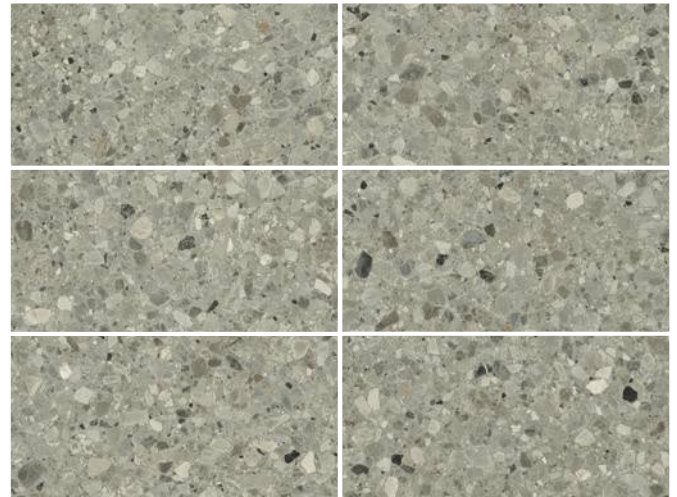

rock light 

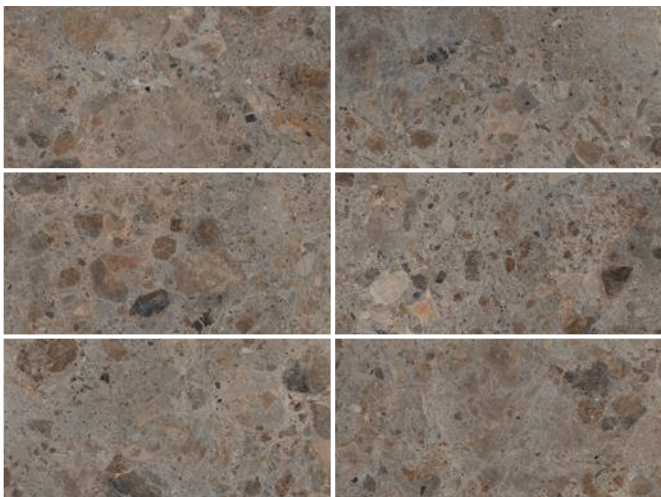

ceppo dark 

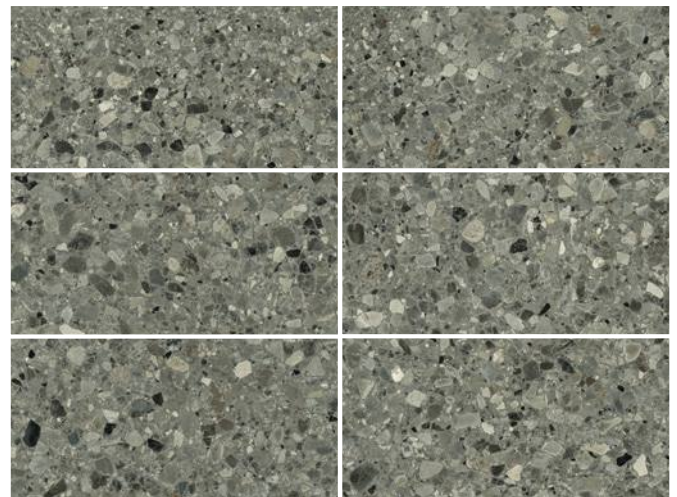

rock dark 



natural 



honey 

# OHIO

## *Versatile wall and floor concept with a minimalist concrete look*

Timelessly modern or urban-minimalistic? Both are possible with OHIO! Featuring nonvitreous tiles for the wall and VilboStone porcelain stoneware tiles for floors and walls, this tile range is a genuine all-rounder with its minimalist concrete look. Whether in the bathroom, the kitchen or throughout the living area – OHIO by Tiles introduces design aspects found in contemporary architecture into individual home settings.

The high-quality porcelain stoneware is available in five harmoniously coordinated shades and the nonvitreous in two bright, neutral shades: creme and beige have a pleasantly warm charm, while light grey, grey and dark grey are pleasantly cool and cosy at the same time.

The latest formats also fit together perfectly: 30 x 60-cm wall and floor tiles can be laid perfectly in a joint-coordinated tiling pattern. The 45 x 45-cm and 60 x 60-cm squares in porcelain stoneware are also suitable for expressive floor surfaces. As a special boon: With R10/B slip resistance, the large tiles made of VilboStone porcelain stoneware offer the best traction on floor-flush tiled shower trays with few joints: It looks great and is easy to clean.

In a spirit of minimalist understatement and thus perfect for modern interiors – with its simple look of concrete, the OHIO concept for walls and floors by Tiles is a superb fit for modern bathrooms, living rooms and kitchens. The nonvitreous wall tiles and the tiles made of Vilbo Stone porcelain stoneware, which can be installed on floors and walls, are available in harmoniously coordinated colours that can combine to suit your taste – for a cosy and warm or perhaps a pleasantly cool home interior.

INNOVATIONEN

**Concept<sup>3</sup>**

**CeramicPlus**

**VilboStone**

**VilbostonePlus**

# SILENT MOOD

*Wall tiles in harmonious pastel shades*



The claim is minimalistically purist, the charisma innovative: SILENT MOOD, the wall tile concept by Tiles, brings a gently coloured cement texture to urban facilities. Five delicate pastel colours – light grey, creme, pink, blue and green – create light and fine effects as they project a pleasant, contemporary flair throughout the house.

Urban interior design relies on charming understatement – and so does SILENT MOOD, the wall tile concept by Tiles; its simple cement texture and five fine pastel shades make it perfectly suited for subtle colour designs in contemporary settings. The basic tiles have an airy, natural touch, while the two décor concepts with a structured look draw attention to themselves: with printed, geometric patterns with a 3D effect or as an elaborate relief with a strong touch and feel.

INNOVATIONEN

**CeramicPlus**



The wall tiles made of nonvitreous in the popular 30 x 60 cm format should preferably be laid transversely, in a beautiful, joint-coordinated tiling pattern, or in a brickwork look. The matt, smooth tiles feature the easy-care CeramicPlus finish and can clean up in no time – making them perfect for the bathroom and kitchen, but also in the living area or hallway.

SILENT MOOD basic tiles project an airy naturalness, and the décors rely on a structured look. Choose between a décor with a 3D effect created by structures printed on the ceramic, and a décor with a three-dimensional relief and a pronounced feel. Both décors can be freely and systematically interspersed in the wall design or laid as a wide band – laid across the entire surface, they turn walls into expressive eye-catchers in a room, just asking to be touched.



# SOLID TONES





## Eine Serie – zwei Trendthemen

– SOLIDTONES aus **VilboStone** Feinsteinzeug bietet für kreative Kombinationen sowohl Beton- als auch Steinoptiken. Mit jeweils fünf Farben in acht Formaten sowie Mosaiken, Treppenfliesen und Hohlkehlsocbel ist SOLIDTONES ein umfassendes Fliesenkonzept, das dank der rutschhemmenden Oberflächen auch für Nass- und Barfußbereiche geeignet ist.

## One range – two trend themes

– made of **VilboStone** porcelain stoneware, SOLIDTONES offers creative combinations in looks of concrete and stone. With five colours each and in eight formats, as well as mosaics, stair tiles and cove bases, SOLIDTONES is a comprehensive tile concept with slip-resistant finishes that make it suitable for use in wet and barefoot areas.

## Une série – deux sujets tendance

– SOLIDTONES en grès cérame porcelainé **VilboStone** offre à la fois des looks béton et pierre permettant de réaliser des combinaisons créatives. Avec cinq couleurs déclinées sur huit formats ainsi que des mosaïques, des marches d'escalier et des plinthes à gorge, SOLIDTONES est un concept complet et antidérapant pouvant être également mis en œuvre dans les zones humides et de fréquentation pieds nus.

Alle Formate von SOLIDTONES sind mit der Rutschhemmung R10/B ausgestattet – das Format 30 x 60 cm wahlweise auch mit R11/C. Zum durchdachten Konzept gehören Hohlkehlsokkel, die insbesondere in stark durch Nässe belasteten Bereichen – wie Duschen oder Beckenumgängen in Schwimmbädern – funktionale und langlebige Boden-Wand-Anschlüsse bilden.

All of the SOLIDTONES formats feature R10/B slip resistance – and the 30 x 60 cm format optionally offers R11/C as well. The sophisticated concept includes cove bases that create functional and durable junctions between walls and floors, particularly in wet areas such as showers and swimming pool surrounds.

Tous les formats de la série SOLID TONES sont classés antidérapants R10/B ; le format 30 x 60 cm est en outre également disponible en classe R11/C. Mûrement conçu, ce concept comprend des plinthes à gorge qui forment des transitions sol et mur fonctionnelles et durables dans les zones fortement exposées à l'humidité comme les douches ou les plages de piscines.

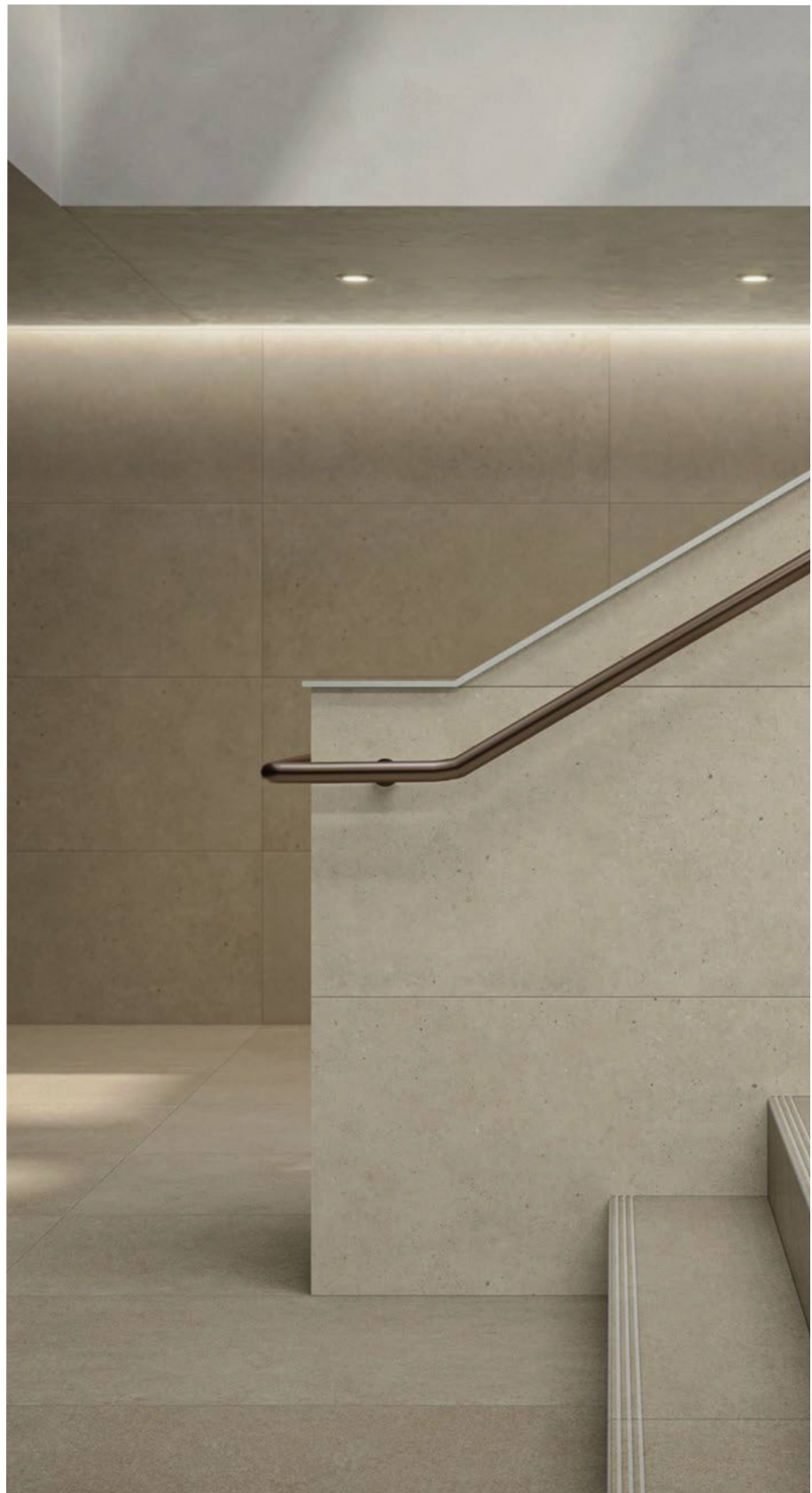

Bodenfliesen | Floor tiles | Carreaux de sol : SOLID TONES warm stone



Alle Formate bis hin zu den Treppenfliesten sind modular aufeinander abgestimmt und können im Fugenschnitt passend miteinander kombiniert werden. Mit den 120 cm breiten Treppenfliesten sind attraktive und funktionale Treppengestaltungen mit wenigen Fugen möglich. Für ein sicheres Begehen sorgen neben den Oberflächen in R10/B auch die gerundete Stufenvorderkante und die gefrästen Rillen.

All of the formats, even the stair tiles, form part of a modular concept and can be combined to fit together in a joint-coordinated pattern. 120 cm in width, the stair tiles permit attractive and functional staircase designs with few joints. In addition to finishes in R10/B, the rounded-front stair nosing and milled grooves ensure safe footing.

Tous les formats, y compris les marches d'escalier, sont modulaires entre eux et peuvent être posés à joints réguliers en combinant harmonieusement plusieurs formats. Les marches en 120 cm de largeur permettent de réaliser des escaliers esthétiques et fonctionnels avec peu de joints. Leur surface antidérapante classée en R10/B, leur bord d'attaque arrondi et les rainures fraisées assurent une bonne sécurité d'utilisation.







# SOLID TONES

**Grundfliesen aus Feinsteinzeug (für Wand und Boden geeignet)**  
**Porcelain stoneware basic tiles (suitable for walls and floors)**  
**Carreaux de fond en grès cérame porcelainé (pour sols et murs)**

**VilboStone**  
**VilbostonePlus**

Art. 2310 · 60 x 60 cm

light stone



PS10 2

warm stone



PS70 2

cool stone



PS60 2

pure stone



PS61 2

dark stone



PS62 2

light concrete



PC10 2

warm concrete



PC70 2

cool concrete



PC60 2

pure concrete



PC61 2

dark concrete

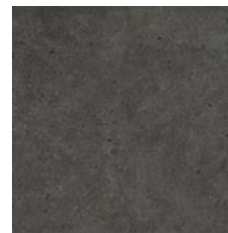

PC62 2

Art. 2737  
 120 x 60 cm

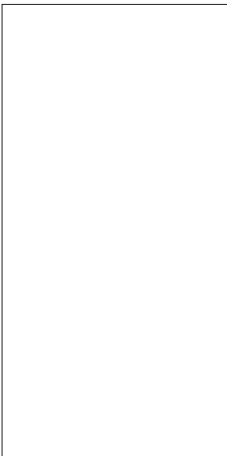

PS10 · PS70 · PS60  
 PS61 · PS62 · PC10  
 PC70 · PC60 · PC61  
 PC62

Art. 2350  
 30 x 120 cm



PS10 · PS70 · PS60  
 PS61 · PS62 · PC10  
 PC70 · PC60 · PC61  
 PC62

Art. 2732  
 30 x 120 cm

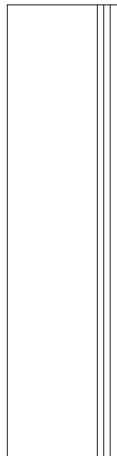

PS10 · PS70 · PS60  
 PS61 · PS62 · PC10  
 PC70 · PC60 · PC61  
 PC62

Treppenauftritt  
 Stair tread  
 Marche d'escalier

Art. 2685  
 30 x 60 cm



PS10 · PS70 · PS60  
 PS61 · PS62 · PC10  
 PC70 · PC60 · PC61  
 PC62

Art. 2521  
 30 x 60 cm

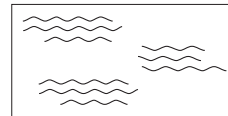

PS10 · PS70 · PS60  
 PS61 · PS62 · PC10  
 PC70 · PC60 · PC61  
 PC62

Art. 2621  
 20 x 60 cm



PS10 · PS70 · PS60  
 PS61 · PS62 · PC10  
 PC70 · PC60 · PC61  
 PC62

Art. 2417  
 10 x 60 cm



PS10 · PS70 · PS60  
 PS61 · PS62 · PC10  
 PC70 · PC60 · PC61  
 PC62

Art. 2578  
 30 x 30 cm



PS10 · PS70 · PS60  
 PS61 · PS62 · PC10  
 PC70 · PC60 · PC61  
 PC62

Art. 2012  
 10 x 10 cm

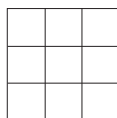

PS10 · PS70 · PS60  
 PS61 · PS62 · PC10  
 PC70 · PC60 · PC61  
 PC62

Art. 2493  
 10 x 30 cm



PS10 · PS70 · PS60  
 PS61 · PS62 · PC10  
 PC70 · PC60 · PC61  
 PC62

Art. 2854  
 5 x 60 cm



PS10 · PS70 · PS60  
 PS61 · PS62 · PC10  
 PC70 · PC60 · PC61  
 PC62

= Rektifiziert · Rectified · Rectifié  
 = Frostbeständig · Frostproof  
 Non gélif DIN EN ISO 10545-12

R10 = Rutschhemmung im gewerblichen Bereich  
 Anti-slip in workshop areas  
 R11 = Rutschhemmung im gewerblichen Bereich  
 Propriétés antidérapantes dans les domaines industriels

B = Rutschhemmung im Barfußbereich  
 Anti-slip in barefoot areas  
 C = Rutschhemmung im Barfußbereich  
 Propriétés antidérapantes dans les zones pieds nus

1 2 3 4 = Variationsvielfalt · Shade variation  
 Variation chromatique

# SOLID TONES

Variationsvielfalt | Shade variation | Variation chromatique



light stone



light concrete



warm stone



warm concrete



cool stone



cool concrete



pure stone

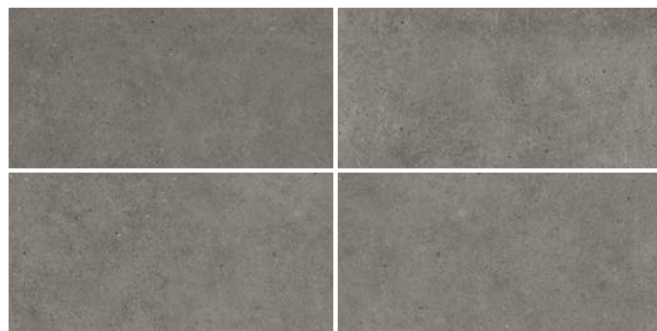

pure concrete



dark stone



dark concrete





SPARKS





## Alte Handwerkskunst funktional interpretiert

– die **VilboStone** Feinsteinzeugserie SPARKS überzeugt mit authentisch anmutenden Terrazzo-Designs im Großformat 120 x 120 cm. Damit steht die Serie für ästhetisch überzeugende Lösungen im Stil der überlieferten Handwerkskunst. Die vier Designs bilden optische Abstufungen von feinen bis hin zu lebhaft ausgearbeitetem Oberflächen. Bezogen auf die Pflegeleichtigkeit übertreffen die Fliesen ihre natürlichen Vorbilder. Sie sind mit der Oberflächenausrüstung **VilbostonePlus** versehen, die die Fleck- und Schmutzempfindlichkeit deutlich reduziert. Dies macht sie zu einem ausgezeichneten Belag für die Gastronomie, für Bürohäuser, Hotels oder Ladengeschäfte.

## Time-honoured craftsmanship, functionally interpreted

– SPARKS, the range in **VilboStone** porcelain stoneware, is impressive for its authentic-looking terrazzo designs in a large, 120 x 120 cm format. Hence, the range stands for aesthetically appealing solutions in the style of traditional craftsmanship. The four designs create visual gradations in finishes that range from fine to vividly crafted. When it comes to ease of care, these tiles outperform their natural role models. They feature **VilbostonePlus** surface protection, which significantly reduces the tiles' susceptibility to staining and soiling. This makes them an excellent covering for use in restaurants, office buildings, hotels or shops.

## Interprétation fonctionnelle du savoir-faire artisanal traditionnel

– la série SPARKS en grès cérame porcelainé **VilboStone** séduit par ses motifs s'inspirant du granito authentique et déclinés sur le grand format 120 x 120 cm. Cette série propose ainsi des solutions esthétiquement séduisantes dans le style de l'artisanat traditionnel. Les quatre designs forment des dégradés visuels allant des surfaces finement travaillées à des finitions plus vives. En termes de facilité d'entretien, ces carreaux surpassent leurs modèles naturels. Ils bénéficient de la finition **VilbostonePlus** qui réduit considérablement leur sensibilité aux taches et aux salissures. Ces propriétés font d'eaux un revêtement idéal pour les restaurants, les immeubles de bureaux, les hôtels ou encore les magasins.





# SPARKS

**Grundfliesen aus Feinsteinzeug (für Wand und Boden geeignet)**  
**Porcelain stoneware basic tiles (suitable for walls and floors)**  
**Carreaux de fond en grès cérame porcelainé (pour sols et murs)**

**VilboStone**  
**VilbostonePlus**

Art. 2757 · 120 x 120 cm

pearl grey

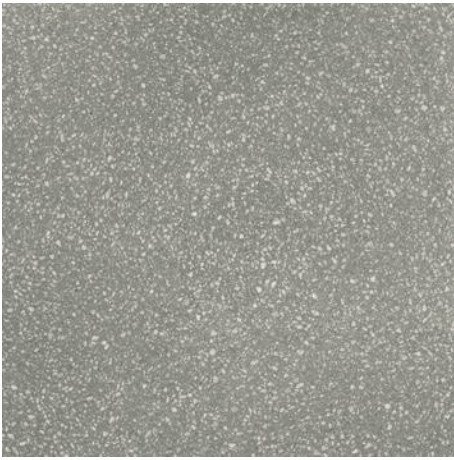

TE60 2  
 R10 A

city grey



TE61 2  
 R10 A

moon grey



TE70 2  
 R10 A

cosmic black

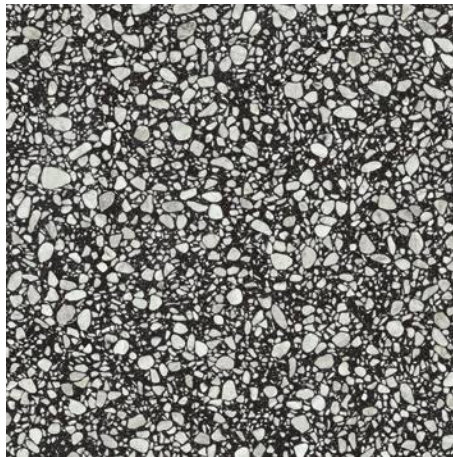

TE90 2  
 R10 A

Art. 2877

5 x 120 cm

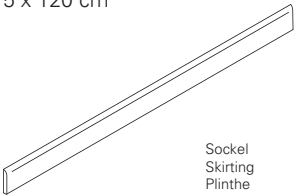

Sockel  
 Skirting  
 Plinthe

TE60 · TE61

TE70 · TE90



= Rektifiziert · Rectified · Rectifié  
 = Frostbeständig · Frostproof  
 Non gélif DIN EN ISO 10545-12

R10 = Rutschhemmung im gewerblichen Bereich  
 Anti-slip in workshop areas  
 Propriétés antidérapantes dans les domaines industriels

A = Rutschhemmung im Barfußbereich  
 Anti-slip in barefoot areas  
 Propriétés antidérapantes dans les zones pieds nus

1 2 3 4 = Variationsvielfalt · Shade variation  
 Variation chromatique



# SPARKS

Variationsvielfalt | Shade variation | Variation chromatique



pearl grey

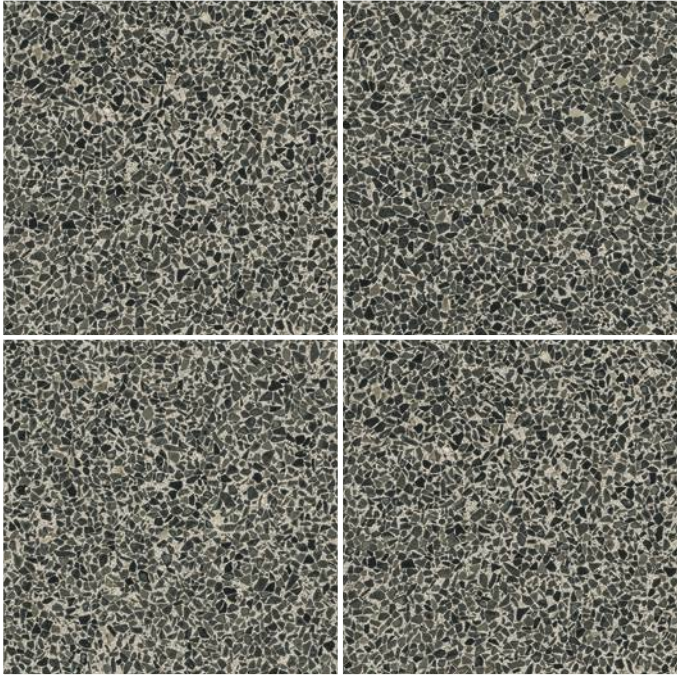

city grey

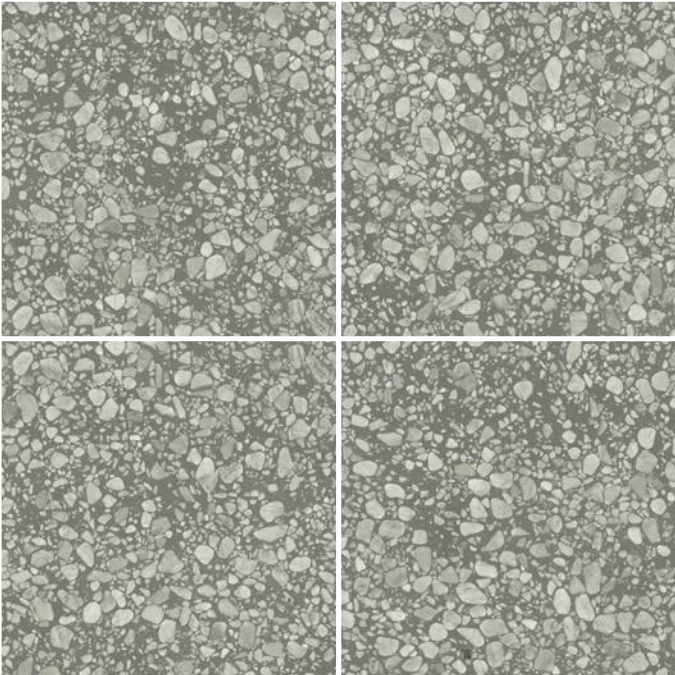

moon grey

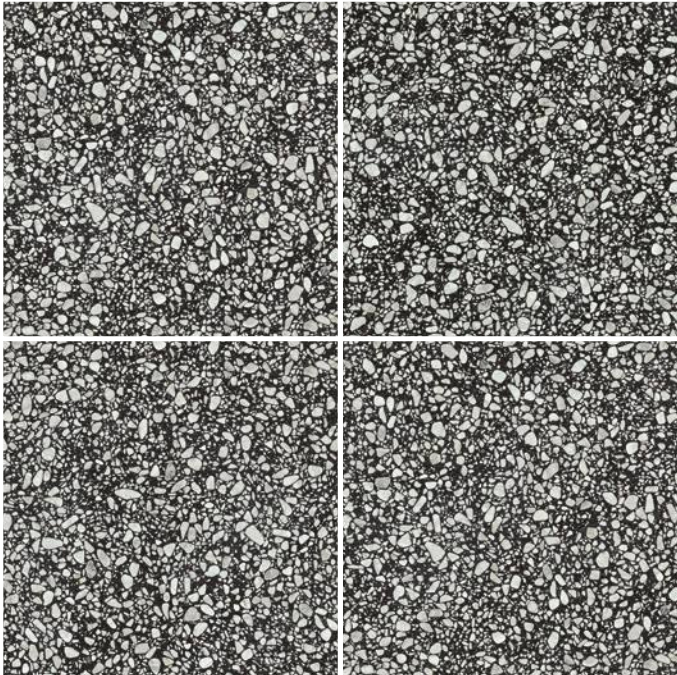

cosmic black





Villeroy & Boch  
1748

BOURGOGNA

## Der neue Modern Country Look

– puristisch und behaglich in einem. Die **VilboStone** Feinsteinzeugserie **BOURGOGNA** schafft mit authentischen Farben, mit großen Formaten und einem außergewöhnlichen Hexagonal-Dekor einen zeitgemäßen Stil. Das Oberflächendesign und die Farbvarianten lehnen sich an Kalk- und Sandstein an – jeweils individuell und neu interpretiert und stets von der besonderen Nähe zur Natur geprägt.

## The new modern country look

– puristic and cosy, all in one. With authentic colours, large formats and an extraordinary hexagonal décor, the **BOURGOGNA** range of tiles in **VilboStone** porcelain stoneware creates a contemporary style. The surface-finish design and the colour variations are inspired by limestone and sandstone – each with a fresh and individual reinterpretation and always characterised by a special closeness to nature.

## Le nouveau look country moderne

– est à la fois épuré et confortable. La série **BOURGOGNA** en grès cérame porcelainé **VilboStone** crée un style contemporain avec ses couleurs authentiques, ses grands formats et son extraordinaire décor hexagonal. Le design de la surface et les différentes couleurs s'inspirent du calcaire et du grès – chaque fois individuellement réinterprété mais toujours marqué par sa proximité particulière avec la nature.













Die optische Großzügigkeit der Formate 80 x 80 cm und 60 x 120 cm unterstützt die natürliche Wirkung des hochwertigen **VilboStone** Feinsteinzeugs. Ausgestattet mit der Rutschhemmungsklasse R10/B sind auch die Fliesen im Großformat eine trittsichere Alternative für bodenebene Duschen. Der relativ geringe Fugenanteil wirkt elegant und sorgt für zusätzliche Pflegeleichtigkeit und Beständigkeit des Belags.

Available in formats of 80 x 80 cm and 60 x 120 cm, the visual impression of spaciousness that these tiles create underscores the natural character of the high-quality **VilboStone** porcelain stoneware. Featuring R10/B class slip resistance, the large-format tiles also offer a sure-footed alternative for floor-flush shower designs. The relatively low proportion of joints creates an elegant look and provides additional ease of care and robustness to the floor covering.

La générosité visuelle des formats 80 x 80 cm et 60 x 120 cm renforce l'effet naturel et la grande qualité du grès cérame porcelainé **VilboStone**. Classés en catégorie antidérapante R10/B, les carreaux grands formats sont également une option sécurisante pour la réalisation de douches à l'italienne. La proportion de joints relativement faible donne de l'élégance au revêtement et facilite en outre son entretien ainsi que sa durabilité.







# BOURGOGNA

**Grundfliesen aus Feinsteinzeug (für Wand und Boden geeignet)**  
**Porcelain stoneware basic tiles (suitable for walls and floors)**  
**Carreaux de fond en grès cérame porcelainé (pour sols et murs)**

**VilboStone**  
**VilbostonePlus**

Art. 2736 · 60 x 120 cm

beige



DM20



B

greige



DM70



B

grey



DM60



B

anthracite



DM90



B

Art. 2834  
80 x 80 cm

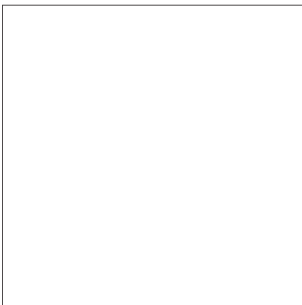

DM20 · DM70

DM60 · DM90

B

Art. 2632  
60 x 60 cm



DM20 · DM70

DM60 · DM90

B

Art. 2184  
26 x 34,5 cm

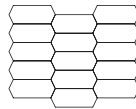

DM20 · DM70

DM60 · DM90

B

Art. 2013  
7,5 x 7,5 cm

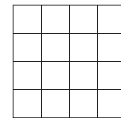

DM20 · DM70

DM60 · DM90

B

Art. 2875  
5 x 60 cm

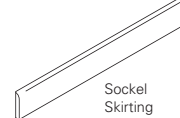

Sockel  
Skirting  
Plinthe

DM20 · DM70

DM60 · DM90

= Rektifiziert · Rectified · Rectifié  
 = Frostbeständig · Frostproof  
 Non gélif DIN EN ISO 10545-12

= Rutschhemmung im gewerblichen Bereich  
 Anti-slip in workshop areas  
 Propriétés antidérapantes dans les domaines industriels

B = Rutschhemmung im Barfußbereich  
 Anti-slip in barefoot areas  
 Propriétés antidérapantes dans les zones pieds nus

= Variationsvielfalt · Shade variation  
 Variation chromatique

# BOURGOGNA

Variationsvielfalt | Shade variation | Variation chromatique



beige



greige



grey



anthracite



Алматы (7273)495-231  
Ангарск (3955)60-70-56  
Архангельск (8182)63-90-72  
Астрахань (8512)99-46-04  
Барнаул (3852)73-04-60  
Белгород (4722)40-23-64  
Благовещенск (4162)22-76-07  
Брянск (4832)59-03-52  
Владивосток (423)249-28-31  
Владикавказ (8672)28-90-48  
Владимир (4922)49-43-18  
Волгоград (844)278-03-48  
Вологда (8172)26-41-59  
Воронеж (473)204-51-73  
Екатеринбург (343)384-55-89

Иваново (4932)77-34-06  
Ижевск (3412)26-03-58  
Иркутск (395)279-98-46  
Казань (843)206-01-48  
Калининград (4012)72-03-81  
Калуга (4842)92-23-67  
Кемерово (3842)65-04-62  
Киров (8332)68-02-04  
Коломна (4966)23-41-49  
Кострома (4942)77-07-48  
Краснодар (861)203-40-90  
Красноярск (391)204-63-61  
Курск (4712)77-13-04  
Курган (3522)50-90-47  
Липецк (4742)52-20-81

Магнитогорск (3519)55-03-13  
Москва (495)268-04-70  
Мурманск (8152)59-64-93  
Набережные Челны (8552)20-53-41  
Нижний Новгород (831)429-08-12  
Новокузнецк (3843)20-46-81  
Ноябрьск (3496)41-32-12  
Новосибирск (383)227-86-73  
Омск (3812)21-46-40  
Орел (4862)44-53-42  
Оренбург (3532)37-68-04  
Пенза (8412)22-31-16  
Петрозаводск (8142)55-98-37  
Псков (8112)59-10-37

Пермь (342)205-81-47  
Ростов-на-Дону (863)308-18-15  
Рязань (4912)46-61-64  
Самара (846)206-03-16  
Саранск (8342)22-96-24  
Санкт-Петербург (812)309-46-40  
Саратов (845)249-38-78  
Севастополь (8692)22-31-93  
Симферополь (3652)67-13-56  
Смоленск (4812)29-41-54  
Сочи (862)225-72-31  
Ставрополь (8652)20-65-13  
Сургут (3462)77-98-35  
Сыктывкар (8212)25-95-17  
Тамбов (4752)50-40-97

Тверь (4822)63-31-35  
Тольятти (8482)63-91-07  
Томск (3822)98-41-53  
Тула (4872)33-79-87  
Тюмень (3452)66-21-18  
Ульяновск (8422)24-23-59  
Улан-Удэ (3012)59-97-51  
Уфа (347)229-48-12  
Хабаровск (4212)92-98-04  
Чебоксары (8352)28-53-07  
Челябинск (351)202-03-61  
Череповец (8202)49-02-64  
Чита (3022)38-34-83  
Якутск (4112)23-90-97  
Ярославль (4852)69-52-93

Россия +7(495)268-04-70

Казахстан +7(7172)727-132

Киргизия +996(312)96-26-47

[www.santeh.nt-rt.ru](http://www.santeh.nt-rt.ru) | | [vhi@nt-rt.ru](mailto:vhi@nt-rt.ru)